

# CEDAR HOT TUB

Electric / Wood Fired

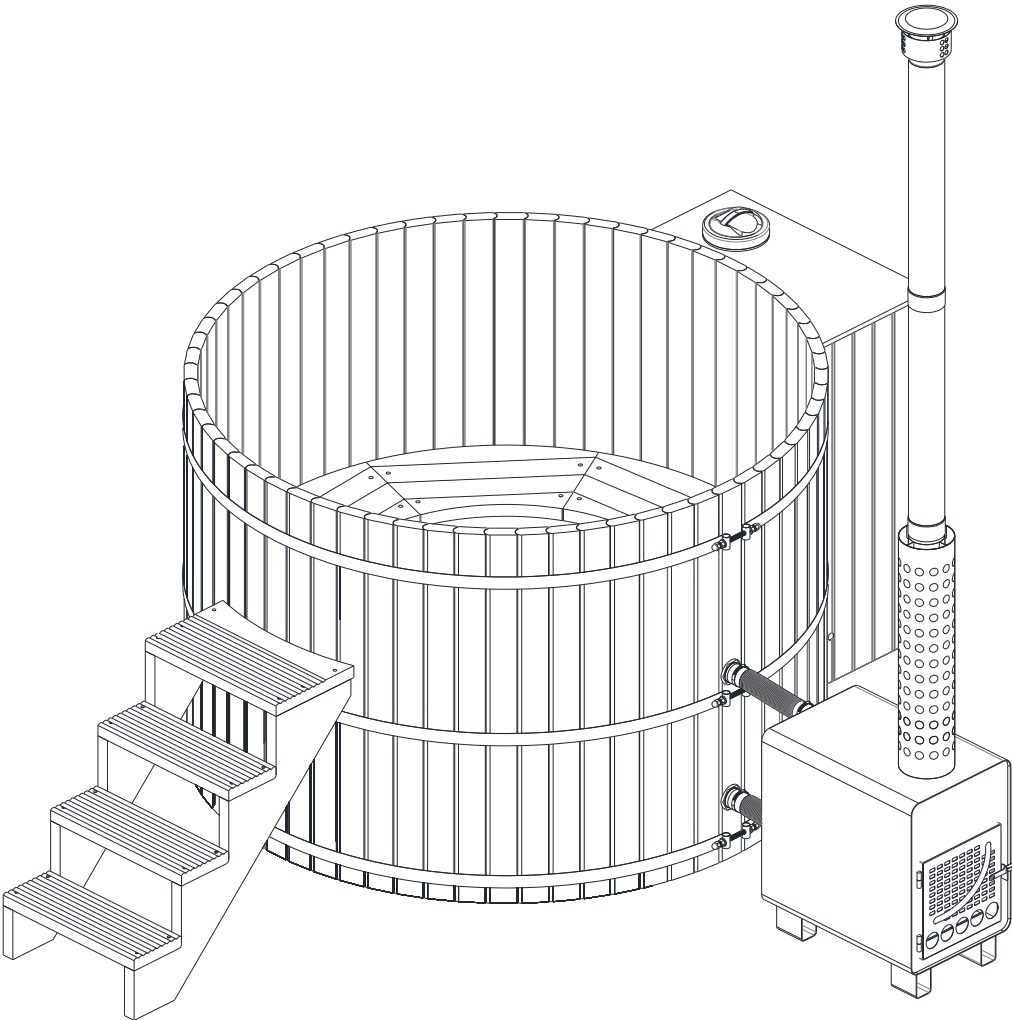

# Contents

WARNINGS-----	1
<b>Safety precautions</b> -----	2
<b>Tools preparation</b> -----	3
<b>Product description</b> -----	4
<b>Assembly guide</b> -----	5
Hot tub base assembly-----	5
Hot tub stave assembly-----	9
System cabinet assembly-----	12
Wood fired stove installation-----	18
Ladder assembly-----	21
Bench assembly-----	22
Insulation cover assembly-----	24
Cedar skirt Installation-----	24
◇Heat pump connection(Option)-----	30
<b>Operation guide</b> -----	36
ELECTRICAL INSTALLATION-----	36
Wiring Diagram (Mini 1)-----	36
TOPSIDE PANELS-----	37
SV Mini 1 Layout-----	37
LED Indicator Lights-----	37
Display Modes -----	38
◇SETTING THE DATE/TIME -----	39
◇AUTOMATIC HEATING / FILTRATION-----	39
Adjusting Set Temperature -----	40
◇PUMP OPERATION -----	40
SV Mini 1 Pump Buttons -----	41
◇LIGHT OPERATION -----	41
Selecting Light Colour or Effect Mode-----	41
◇KEYLOCK FUNCTION -----	42
◇AUTO DAILY SANITISE-----	43
◇SETUP MENU -----	43
FILT – Filtration (total hours per day)-----	44
SNZE – Sleep Timer -----	44
D.DIS – Default Display -----	44
WIFI – WiFi Setup -----	44
H.PMP – Heat Pump Mode -----	45
H.ELE – Heat Pump + SV Element Boost-----	45
◇OEM CONFIGURATION MENU-----	45
L.SHD – Heater Load Shedding -----	45
EPRM – Factory data reset -----	46
◇DIAGNOSTIC MENU -----	47
◇HEATING CONTROL & PROTECTION-----	47
◇ERROR CODES / TROUBLESHOOTING -----	48
◆ <b>Cleaning and maintenance</b> -----	53
◆ <b>Use instructions</b> -----	54
◆ <b>Precautions</b> -----	54

## WARNINGS

### Risk of electrical shock

- The appliance must be connected to a suitable rated and weather protected power supply. The supply line should be a dedicated power circuit and means for disconnection must be incorporated in the fixed wiring in accordance with your local wiring regulations. The circuit needs to be protected by an RCD and must be installed by a licensed electrician
- Earthed appliances must be permanently connected to fixed wiring (European models only).
- The appliance contains no serviceable parts. Do not attempt service the control system. Contact your dealer or authorised service agent for assistance.
- Turn the mains power OFF before servicing appliance or modifying any cable connection.
- Low voltage or improper wiring may cause damage to this appliance. Read and follow all wiring instructions when connecting to power supply.
- If the supply cord is damaged it must be replaced by the manufacturer, its service agent, licensed electrician or similarly qualified persons in order to avoid a hazard.
- To prevent electric shock hazard and/or water damage to this appliance, all unused receptacles must have a water proof seal in place.
- Parts incorporating electrical components must be located or fixed so that they cannot fall into the bath or spa.
- Parts containing live parts, except parts supplied with safety extra-low voltage not exceeding 12V must be inaccessible to a person in the bath or spa.
- This appliance must NOT be installed in proximity to highly flammable materials.
- Water temperature in excess of 38°C may cause hyperthermia (heat stress).
- It is the spa manufacturer's and/or installer's responsibility to select suitable loads and configure load shed settings (if required) to ensure the system does not exceed its rated maximum total load.
- It is the owners responsibility to ensure the sub-base can support the expected load of the spa that can be up to 3500kg.
- An adequate drainage system must be provided if the equipment is to be installed in a pit.
- This appliance is not intended for use by persons (including children) with reduced physical, sensory or mental capabilities, or lack of experience and knowledge, unless they have been given supervision or instruction concerning use of the appliance by a person responsible for their safety.
- Children should be supervised at all times

**• ALL ELECTRICAL CONNECTIONS MUST BE PERFORMED BY A LICENSED ELECTRICIAN AND MUST CONFORM TO ALL NATIONAL, STATE AND LOCAL ELECTRICAL CODES IN EFFECT AT THE TIME OF INSTALLATION.**

**• The appliance should be supplied through a residual current device (RCD) having a rated residual operating current not exceeding 30mA.**

**All spas with a water level over 300mm require a safety barrier under the Australian standards, please consult your local council or building surveyor.**

# ◆ Safety precautions

## ▲ Read before using

Thank you for your purchasing one of our hot tubs. Correct installation and maintenance will enable longer service life of the hot tub, please read through the Manual carefully.

## II .Electricity instructions

- The SPA hot tub should be installation and maintenance by licensed qualified professional electrician, non-professional staff shall not disassemble or modify and so on; otherwise the manufacturer would not bear any loss / responsibility thereby.
- We prohibit self-repair of live parts, and prohibit the replacement of the power cord, otherwise it may cause serious harm.
- Do not install the power cord where it can cause a tripping hazard etc, otherwise it may cause electric shock, short circuit or fire.
- In thunderstorms, be sure to turn off the power switch, as lightning may damage the SPA hot tub.
- Do not operate the power switch with wet hands, as there is a risk of electric shock.
- Power: input voltage of 220-240V / 50Hz, according to the product configuration power selection.
- Emergency switch: For non-single-family homes using this equipment, when installed, you should provide a clear label of an emergency switch. The user should be able to touch with the switch without difficulty, and the switch should be installed at least 1.52 meters away and not out of sight of the equipment.

## III . Safety instructions

- Consult doctor before use if you are a pregnant, have a history of heart disease, high and low blood pressure and circulatory system disease.
- Never allow a child use the product alone. To prevent accidents, children should use the product under adult supervision.
- Rationally control product usage time while using the spa since long-term exposure to high temperature will cause an increase in body temperature
- Clean filter regularly with neutral detergent and hose.
- The Insulation cover should be in place cover while the SPA hot tub is not in use.
- Other electric appliances, such as electric light, telephone, radio and TV should be kept away 1.52 m min from around the hot tub.
- Water temperature inside the hot tub shall not exceed 41 Celsius degrees, 38-40 Celsius degrees suitably recommended for a healthy adult. A lower water temperature is more suitable to children after using the hot tub more than 10min.
- To prevent from drowning, NEVER drink alcohol, narcotics or drugs while using the hot tub.
- Prohibit use of pesticides, disinfectants, flammable spray material directly into the system box inside, otherwise it may cause fire or damage to the components.
- Do not place heavy objects on the insulation Cover. Never leave the hot tub empty for any longer the 2 days as this can cause the timber to shrink and can result in leaking.

**Please consult your local council regarding fencing and permit requirements.**

## ▲Read before assembly

**Before assembly, please read the following**

### information and instructions:

- Ground: the assembly site should be flat without any slopes, dents and protrusions, etc. The site should be able to bear 3,500kg.

A concrete slab 120mm min thick with reinforcing mesh is recommended.

- Drainage: the user should install the floor drainage and set up the drainage system according to the location of the product.

- Time: it needs 2 people and 5-8 hours to assemble the product depending on capabilities.

- Tools: tools required are listed below.







- Accessories: hardware accessories are listed in the table below.

Attention: Do not directly unplug when product is being used.

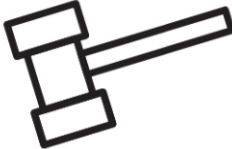
The supply power cable must be replaced at once if there is any damage.

The power should be turned off before you maintain or replace any wire connected to the equipment.

## ◆Tools preparation

<b>Rubber Mallet</b>	<b>Silicone Sealant Gun</b>	<b>Power Drill</b>	<b>Tape Measure</b>
			
<b>Adjustable Wrench</b>	<b>Spirit Level</b>	<b>Pencil</b>	
			

## ■HARDWARE ACCESSORIES

NO.	Component	Specification	Unit	Amount					
				5x3.5	5x4	6x3.5	6x4	7x3.5	7x4
1	Base Connector	M8x100	Pcs	10	10	19	19	19	19
2	Bands	M12x180	Pcs	2	3	4	6	4	6
3	Bench panel	M6x60LN	Pcs	36	36	32	32	36	36
4	Bench feet	M5x50	Pcs	36	36	32	32	36	36
5	Ladder	M5x60	Pcs	18	24	18	24	18	24
6	Ladder Corner Connector	60x60x50	Pcs	2	2	2	2	2	2
7	Ladder Connector Fixings	M5x30	Pcs	10	10	10	10	10	10
8	Cabinet Bolts	M4x16L	Pcs	2	2	2	2	2	2
9	Support bracket screw	M5x30	Pcs	6	6	6	6	6	6
10	Cedar skirt	M4x25	Pcs	6	6	6	6	6	6
		M4x40	Pcs	6	6	6	6	6	6
11	Insulation cover	M3x16	Pcs	8	8	8	8	8	8

# ◆ Product description

## ■ Diagram of water pipes and air pipes

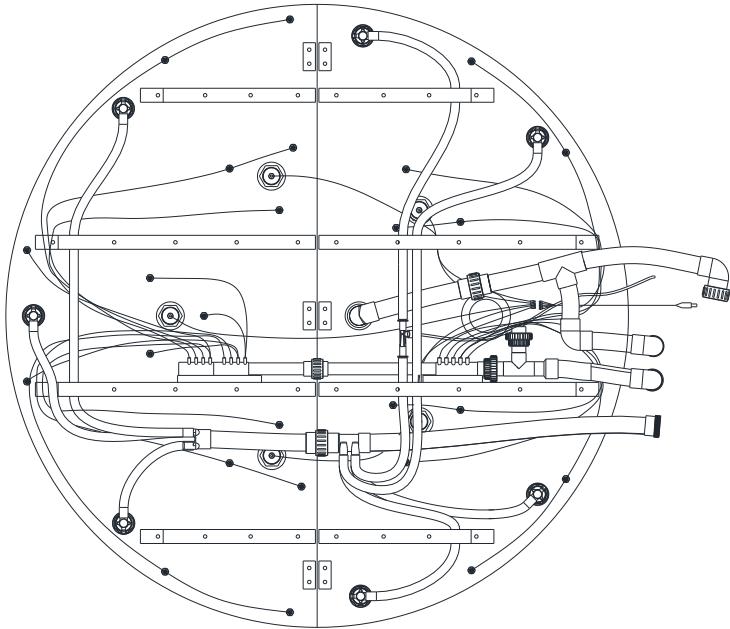

## ■ Control panel description



1. UP button
2. DOWN button
3. OK button
4. Light On/Off
5. Pump A
6. Auxiliary
7. Auto mode LED
8. Heater on LED
9. Sleep Cycle LED

## ■ Description of system components

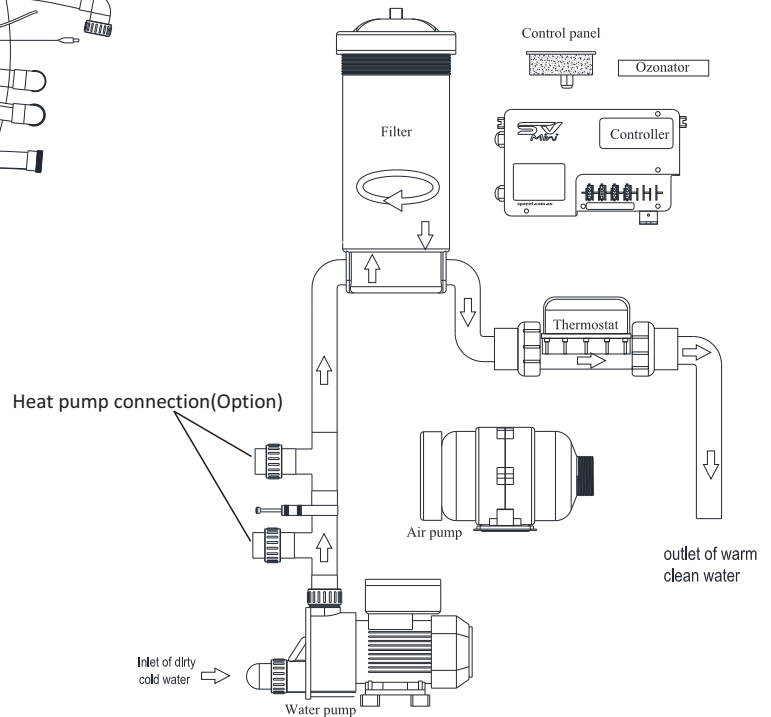

## ■ Description of hot tub components

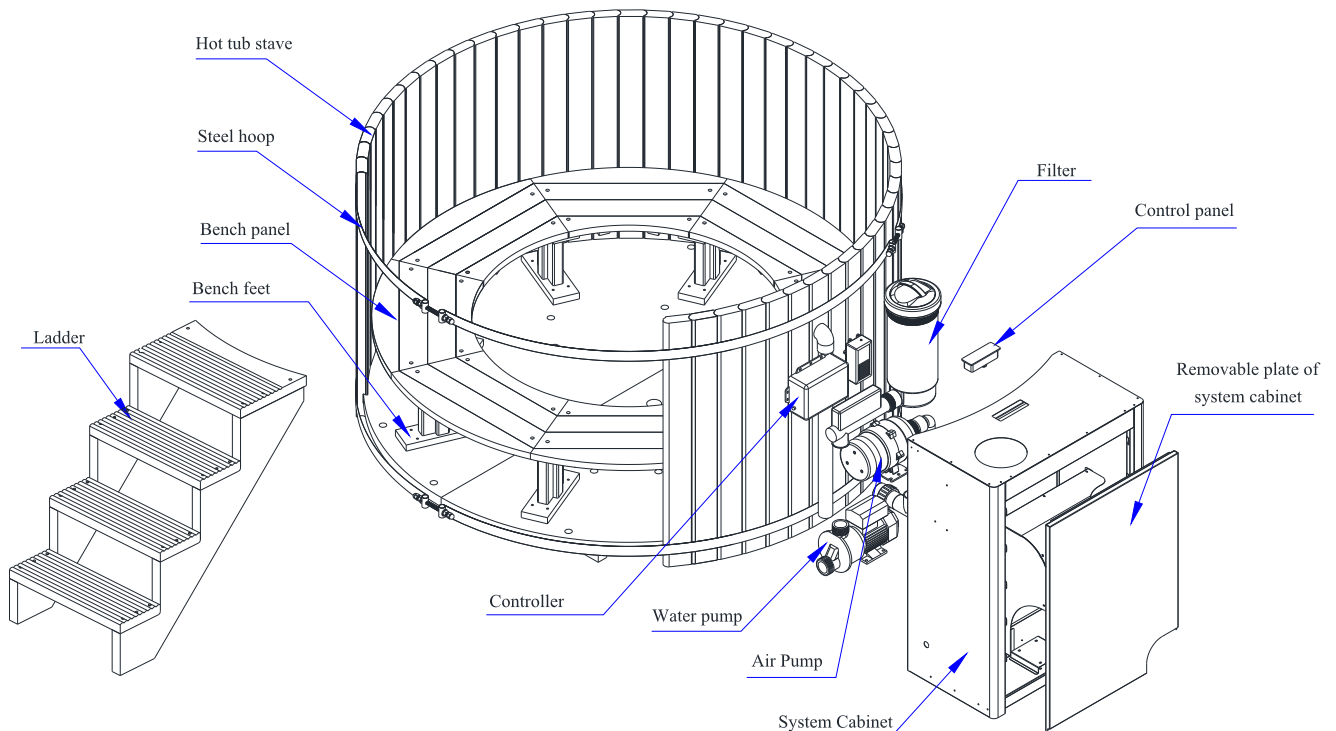

# ◆ Assembly guide

## ◇ Hot tub base assembly

- ① Apply silicone sealant on the groove of the base section.

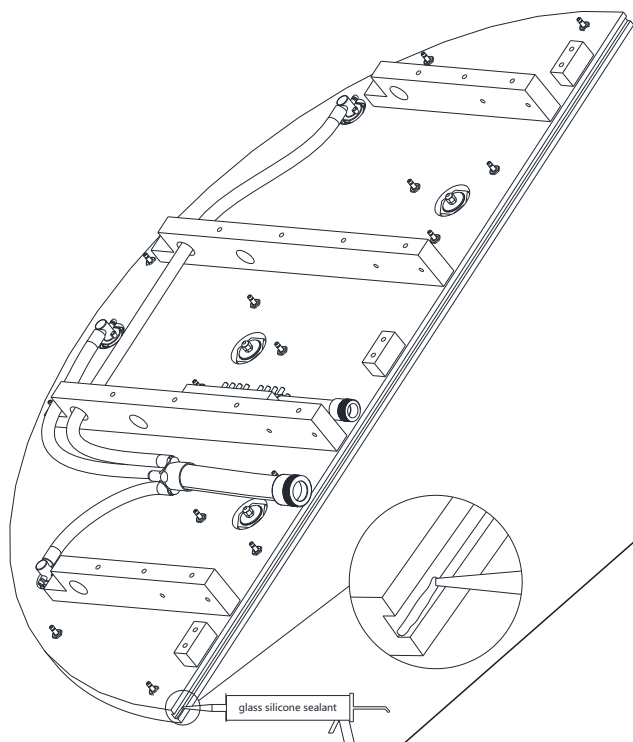

Apply glass silicone  
3mm at two corners



- ② Join the 2 Hot Tub base boards together.

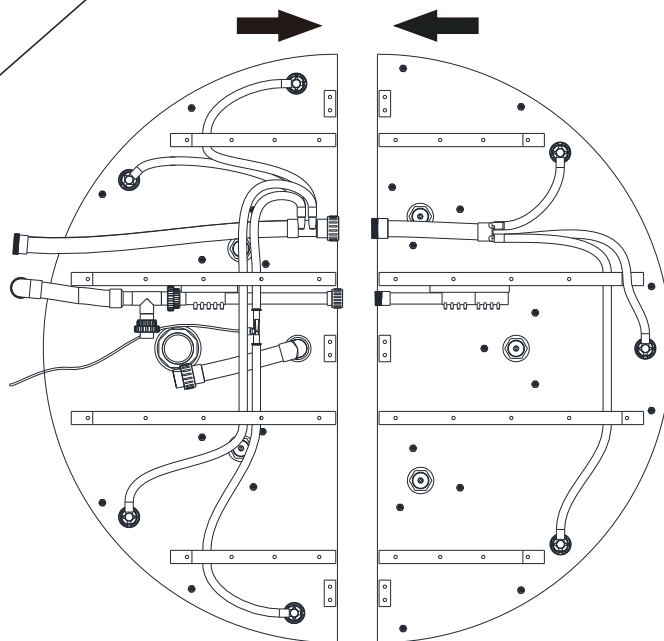

- ③

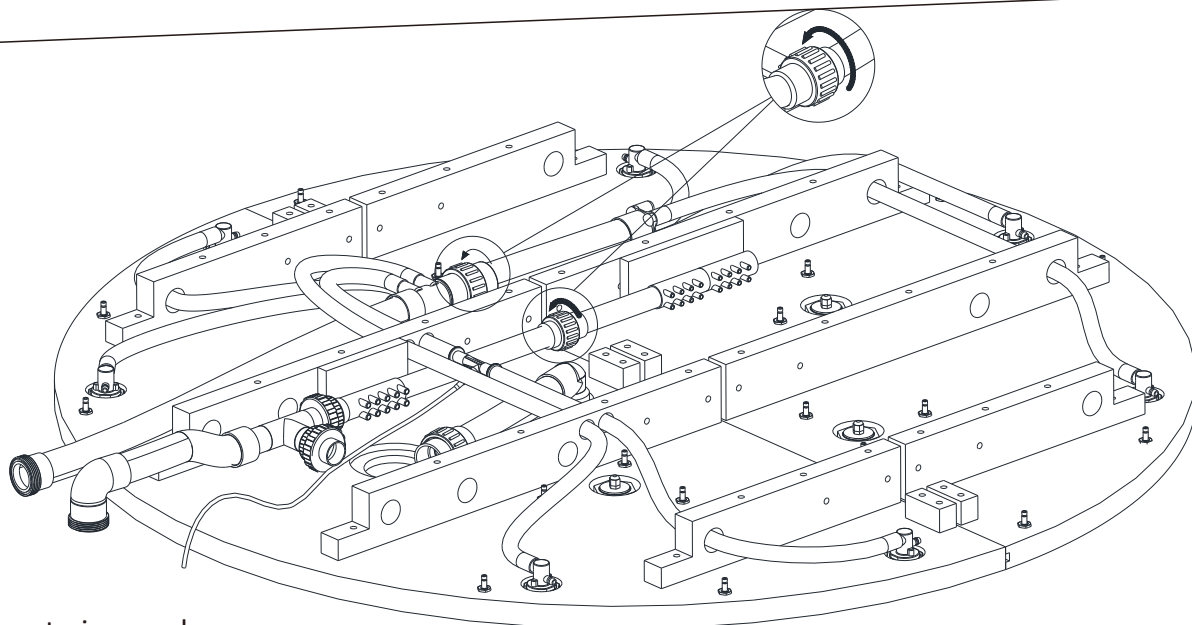

Connect pipework.  
(make sure the rubber O-ring is in place & tighten firmly).

- ④ Place the connecting timber blocks beside hot tub joists.  
Note: The holes should be aligned with hot tub base joists.

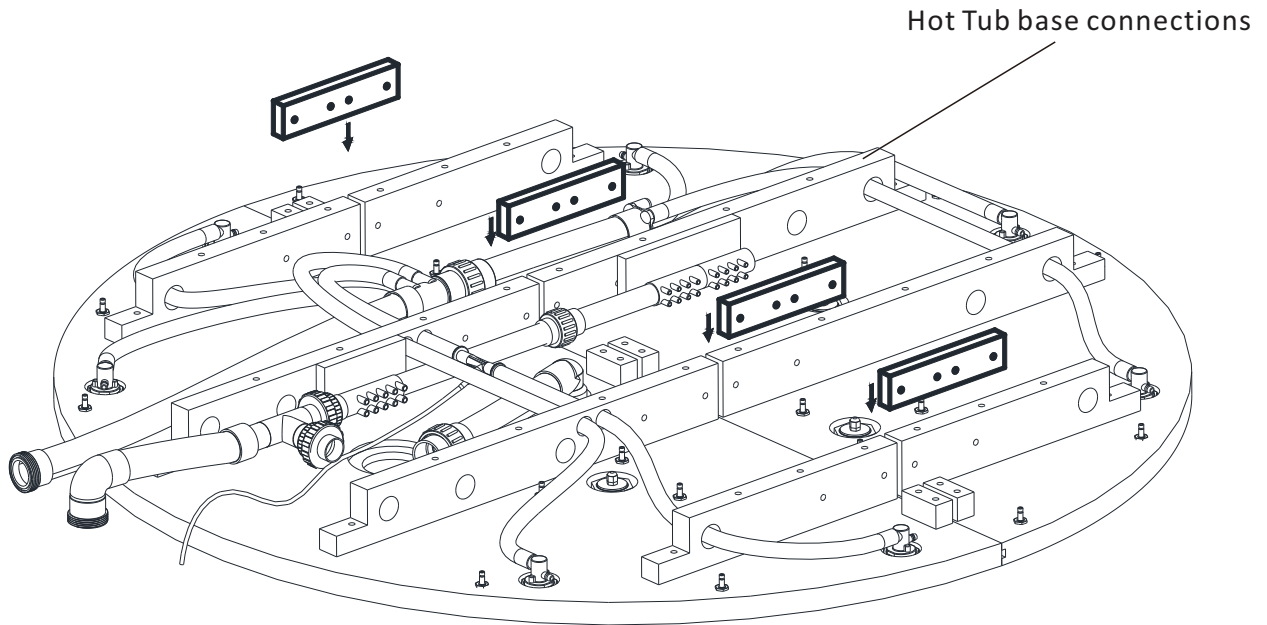

- ⑤ Connect the two hot tub base sections with M8X100 screws.  
Firstly: use one bolt to connect each fixed block and tighten (not too firm)

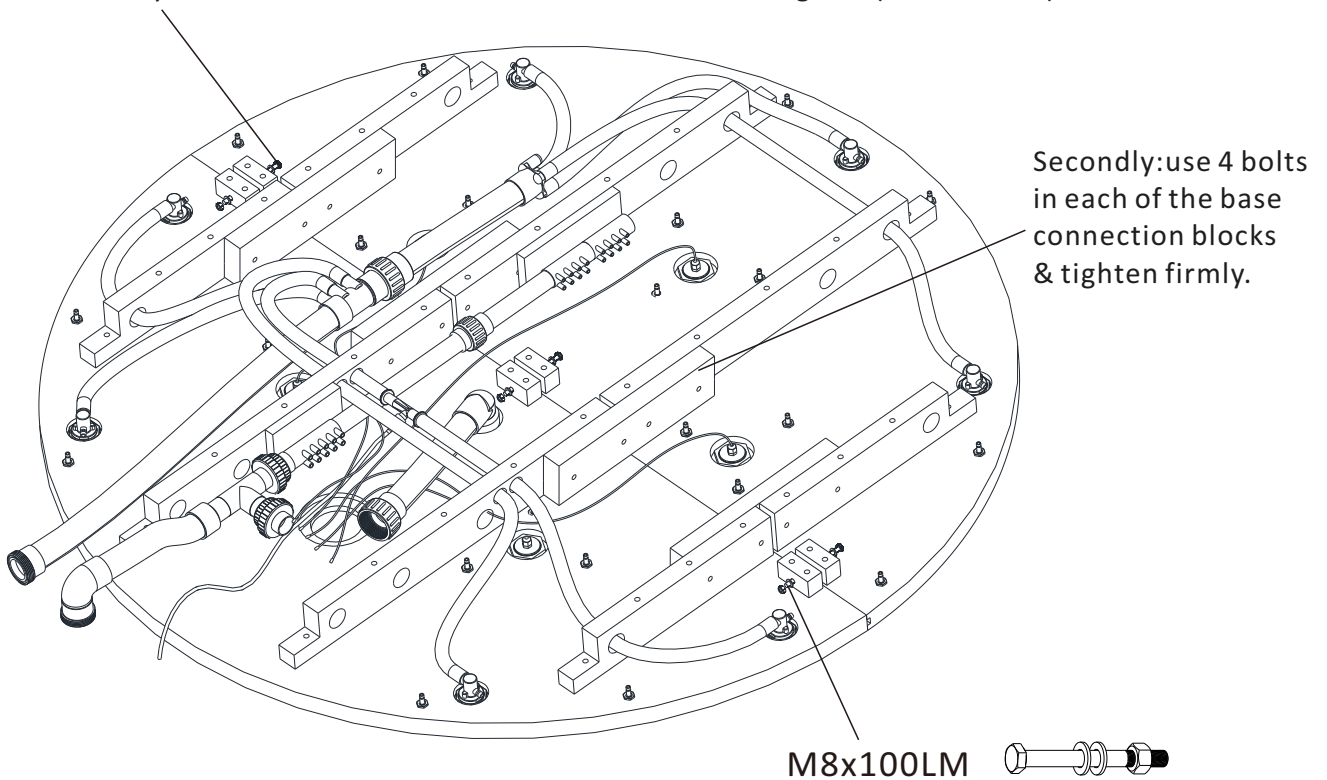



- 6 After connecting the lighting cables together, secure them to the pipes with tape or cable ties.

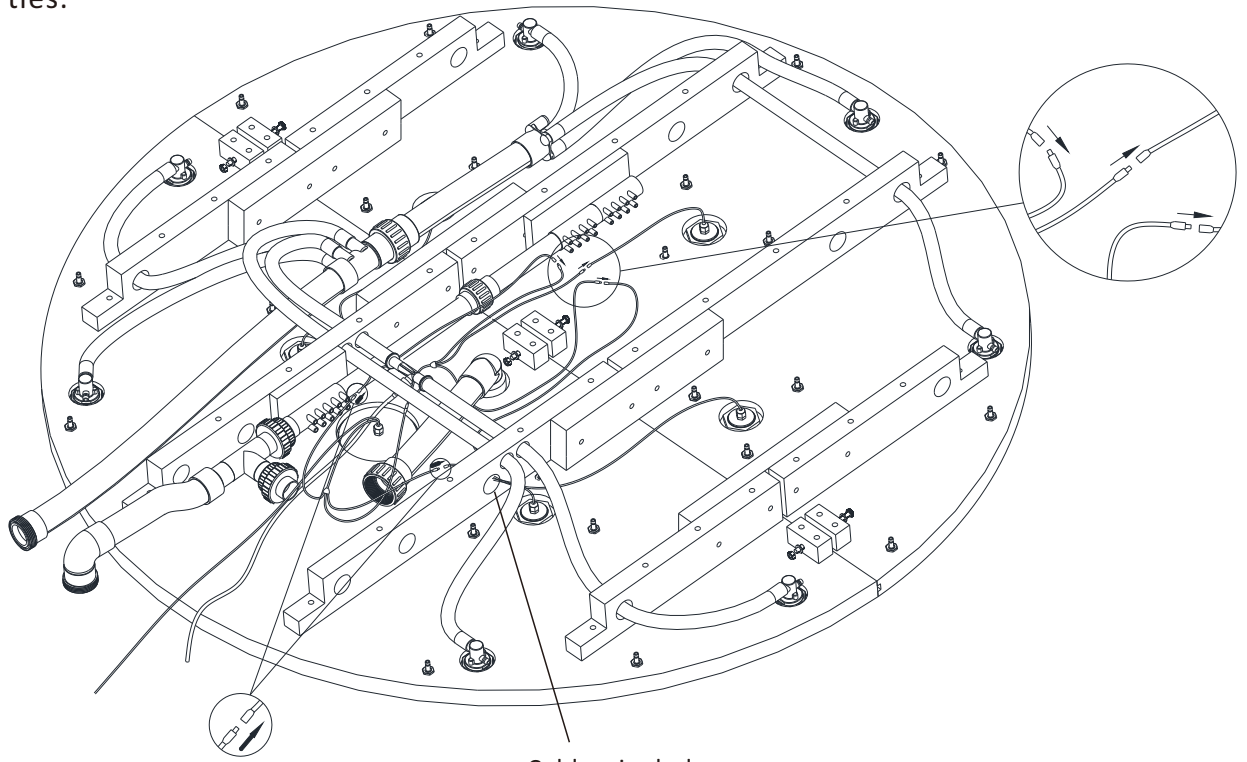

Cable wire hole

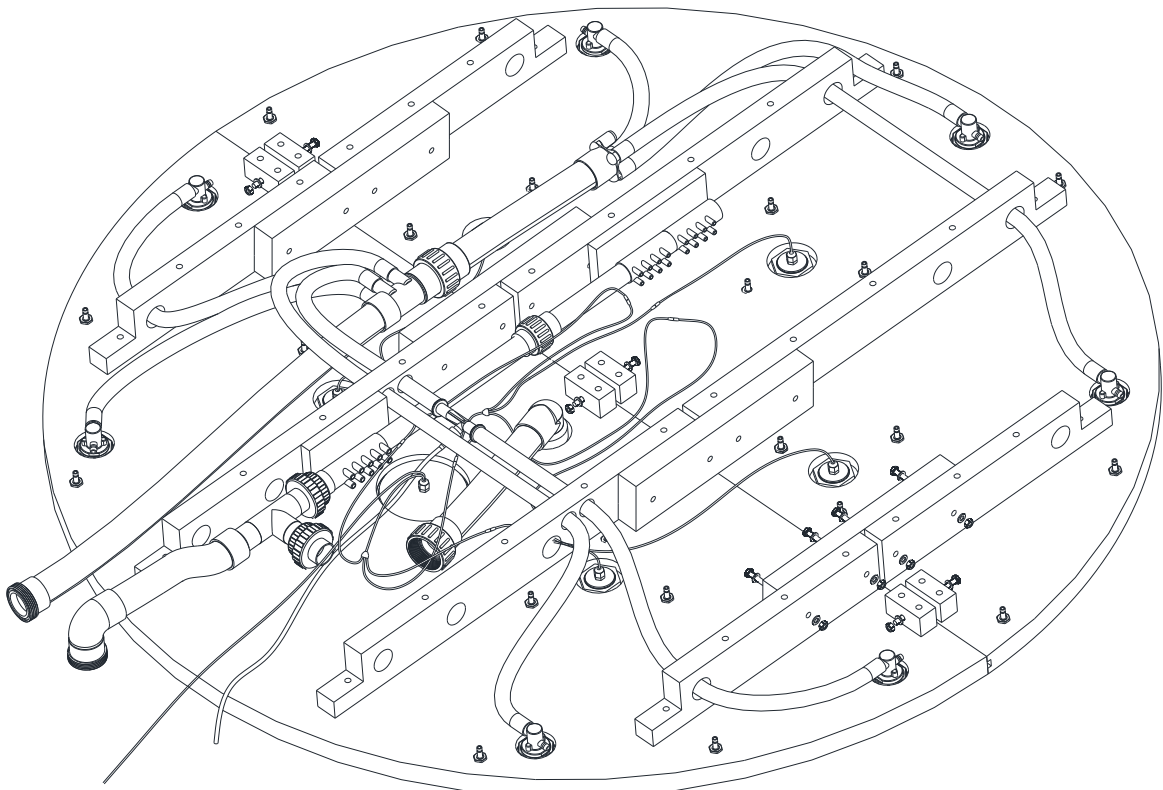

- 7 Connect the return pipe for the control cabinet.

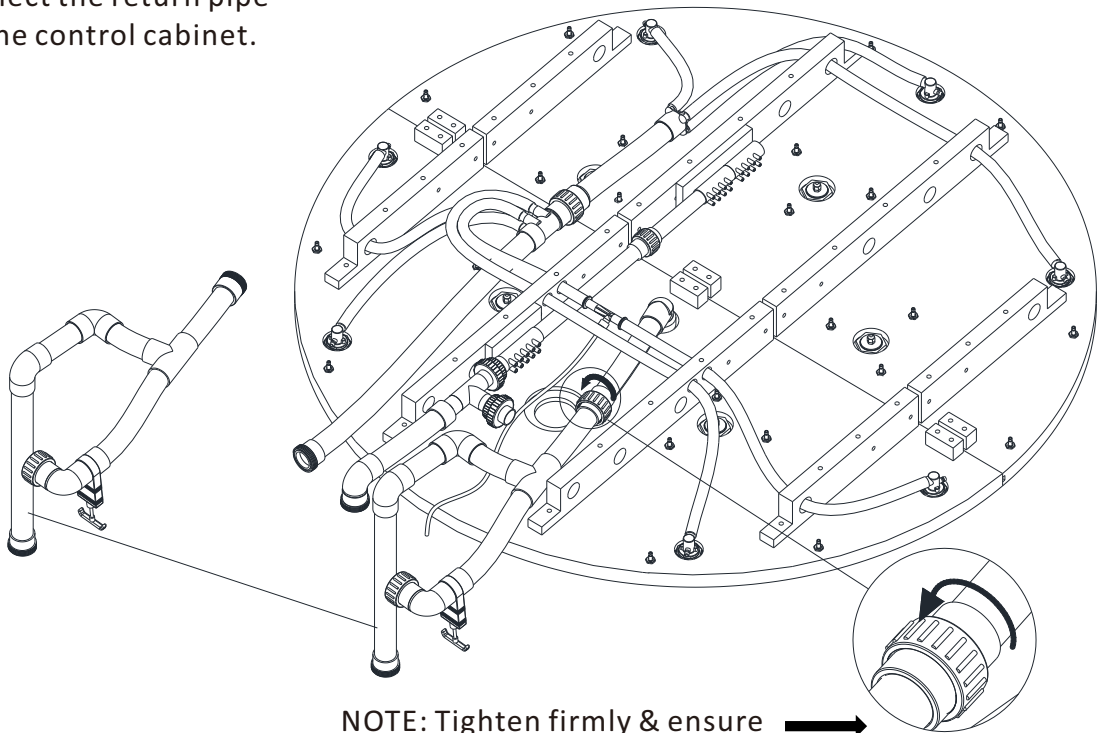

NOTE: Tighten firmly & ensure rubber O-ring is in place.

- 8 Turn over the assembled Hot Tub base and move into the position you want it to be located.  
Note: The Hot Tub has to be placed where it is flat, level and capable of supporting the Tub. We recommend a concrete base (min 120mm thick).

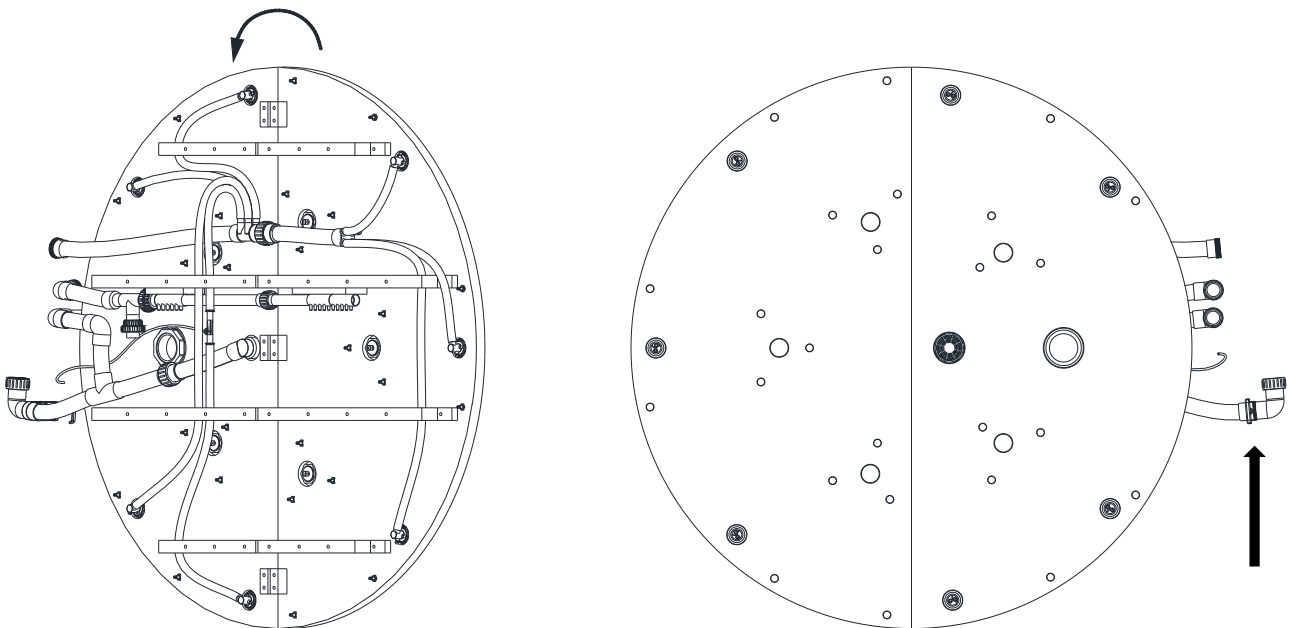

Ensure pipes & light cables are not under the timber supports.

## ◇ Hot tub stave assembly

1

Apply the silicone sealant here. The diameter of the silicone sealant should be 1 cm

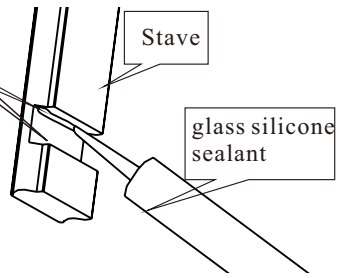

NOTE: There should be a bead top & bottom.

Installation line

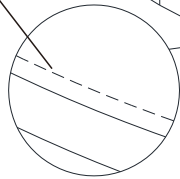

Align groove of the staves to the edge of base, and secure them to the base. Make sure all staves sit just before the installation line. Do not go beyond the installation line as staves need space to pull into later. Assemble the stave with spillway hole before other staves. You can tap the staves with a rubber mallet gently

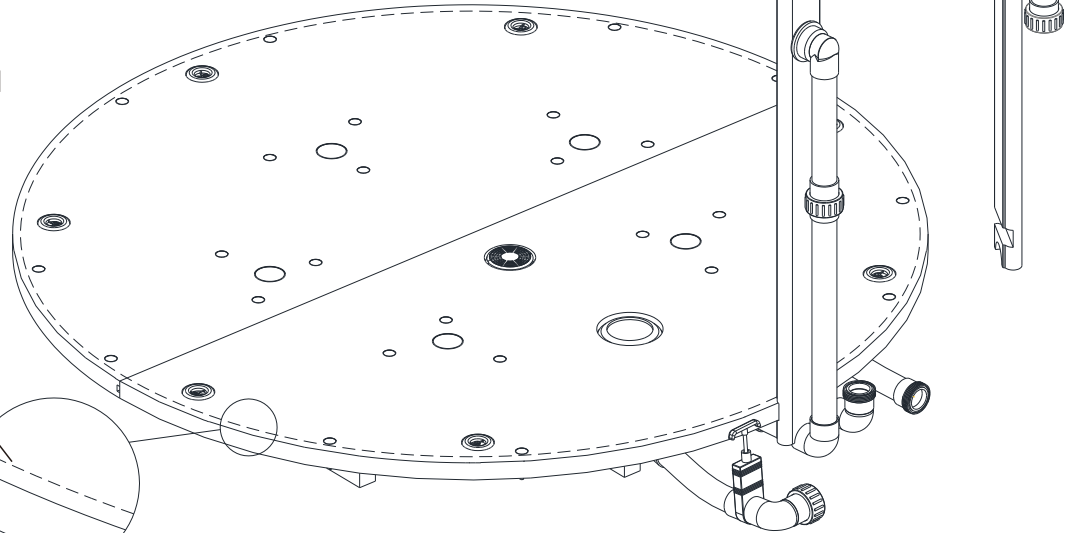

2

Note: If installing a wood fire stove ensure you locate the stave in the correct position.

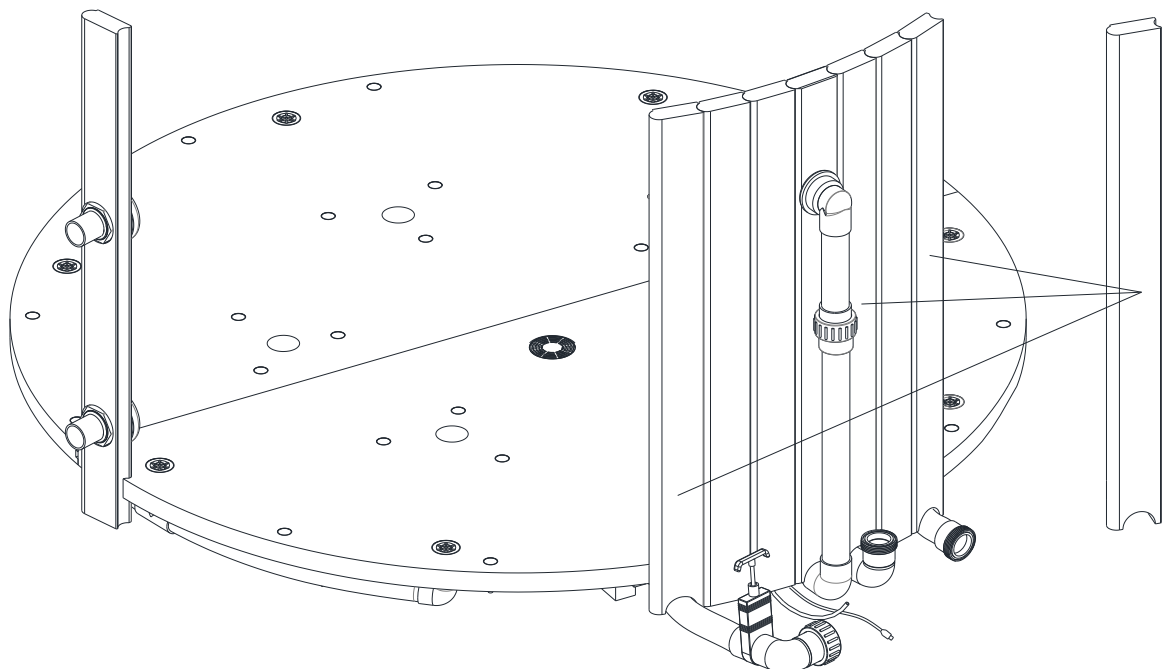

- ③ Choose appropriate width staves when installing the last pieces to complete the Tub. We have provided 3 extra stave pieces; 1pc standard width, 1pc 80mm width and 1pc 65mm width).

Tip: When installing the last stave, you should start from the top and work downwards, gently push staves either side of the gap apart and gently knock the new stave into the installation line.

Specification of Hot Tub	Required amount of Hot Tub stave(pcs)	Total amount of Hot Tub stave(pcs)
5 feet	53	56
6 feet	64	67
7 feet	75	78

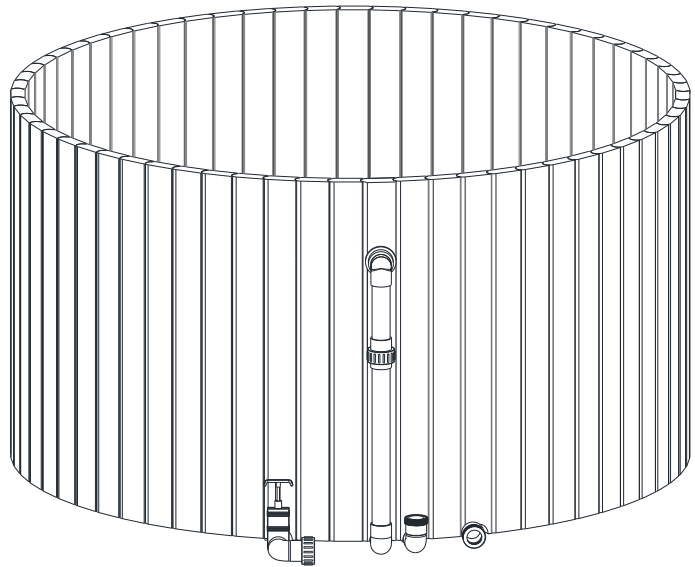

- ④ Carefully open the steel strip, and connect two steel strips of different lengths with the M12 bolt. It is ideal to have these prepared to install immediately after the staves are complete.

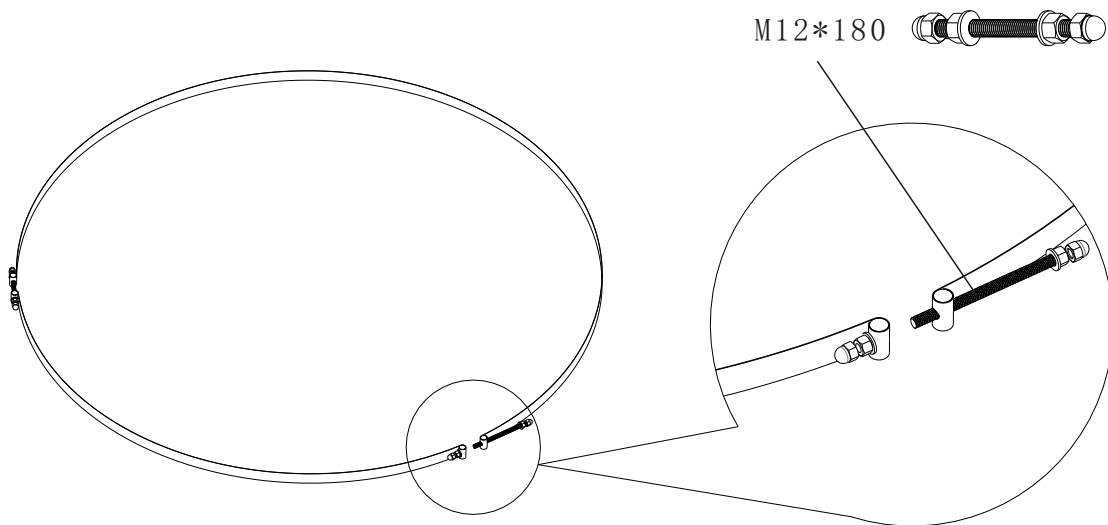

5

Once the Hot Tub staves are in place, the bands need to be added to keep them in position. 2 people are required to tighten the steel strips to the Hot Tub. When tightening the screws, try to knock each stave in tightly with a plastic hammer. When you can hear squeaking the bands are tight enough.

The bottom band should be tightened more firmly than the top and middle band.

The hot tub with a height of 3.5 feet is locked by 2 circles of steel strip, and a height of 4 feet is locked by 3 circles of steel strip.

Size of Hot Tub	Strap length
5feet	One in 4,730 mm
6feet	One in 2,050 mm One in 3,600 mm
7feet	One in 3,000 mm One in 3,600 mm

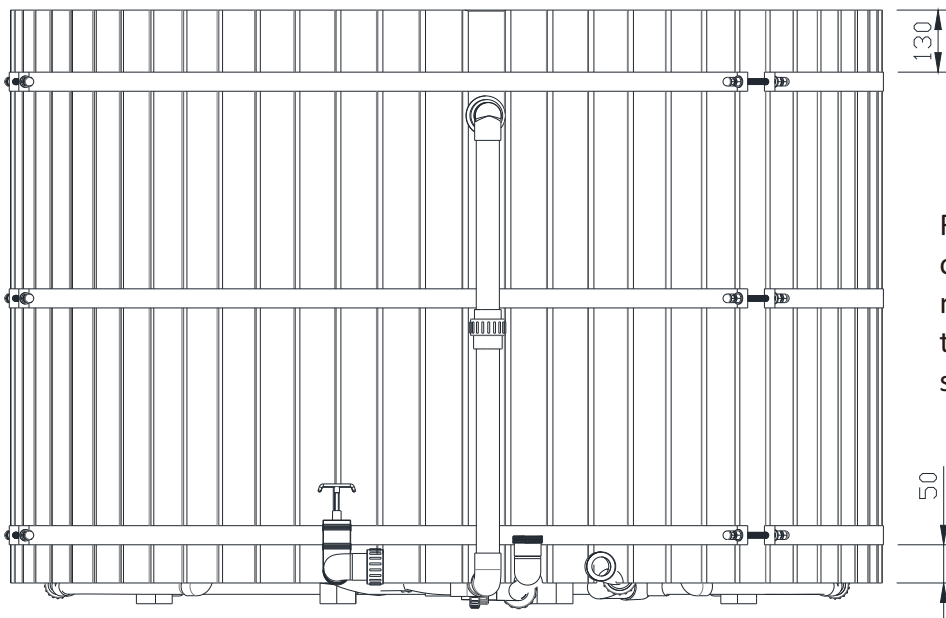

For hot tub with a height of 4 feet, it needs to add the middle steel strip between the top and bottom steel strips

A small bead of silicon between the floor and wall junction is required after assembly.

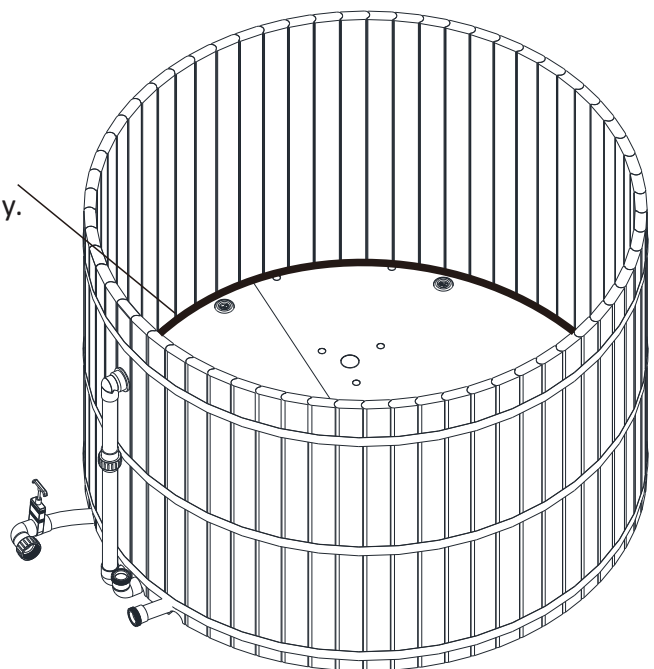

## ◇ System cabinet assembly

- ① After loosening screws, push the front board of the system cabinet downward, then pull outwards, and remove the front panel.

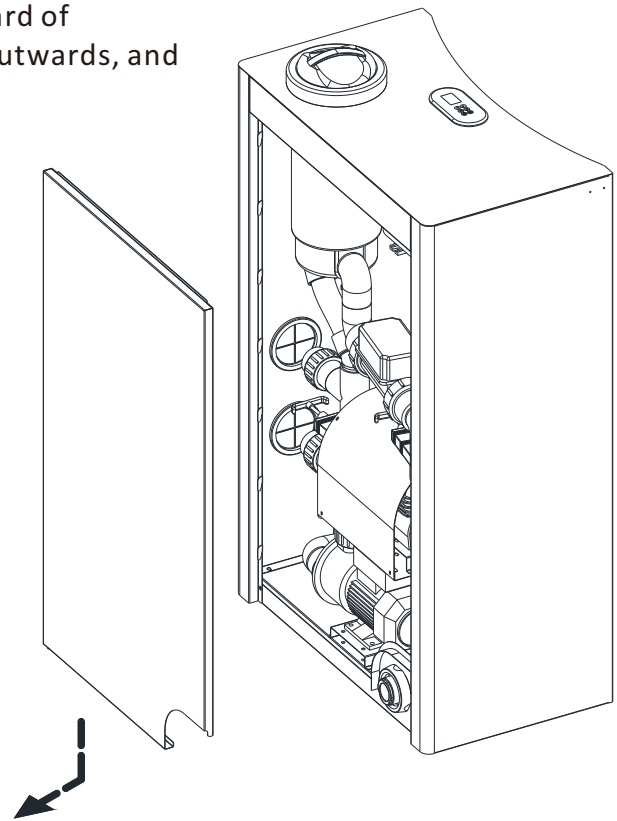
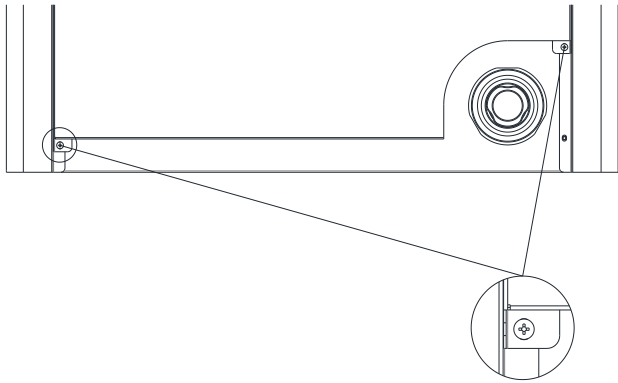

- ② Before installing the system cabinet, position it against the tub.

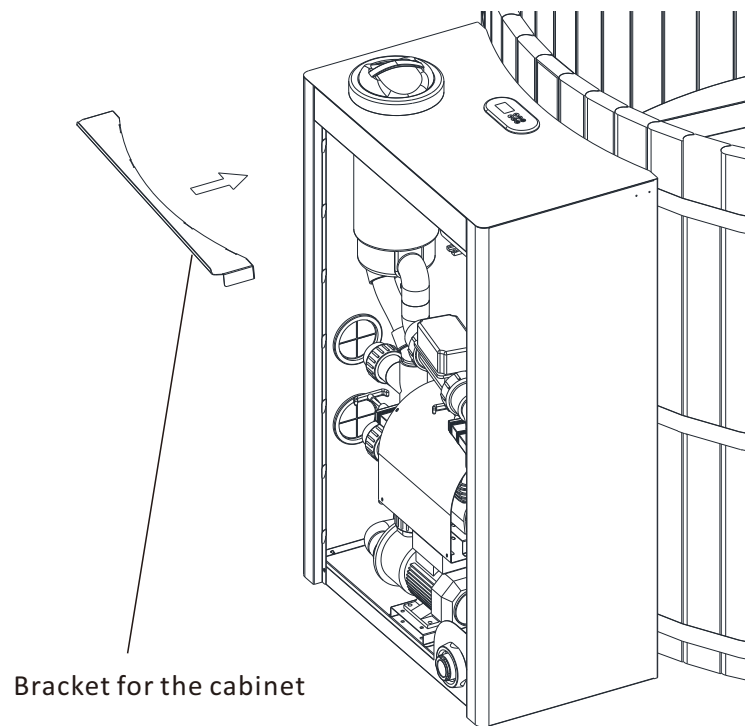
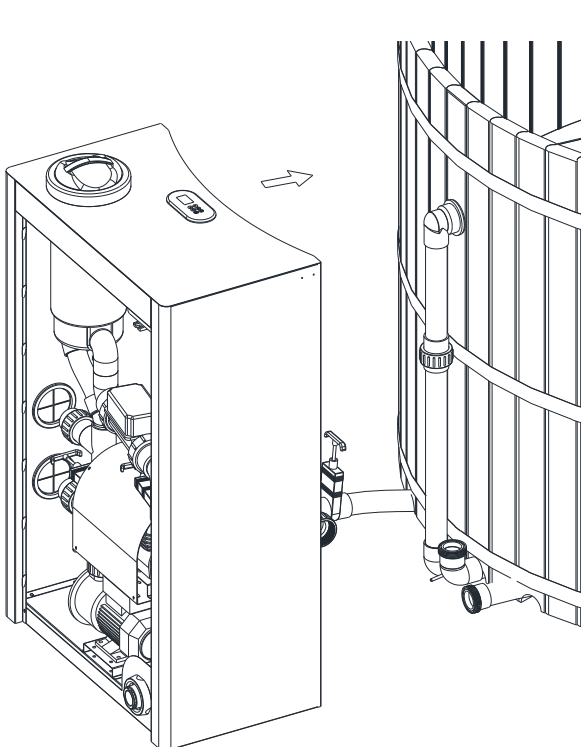

3

Place the system cabinet close to the hot tub; mark the location with a pencil.

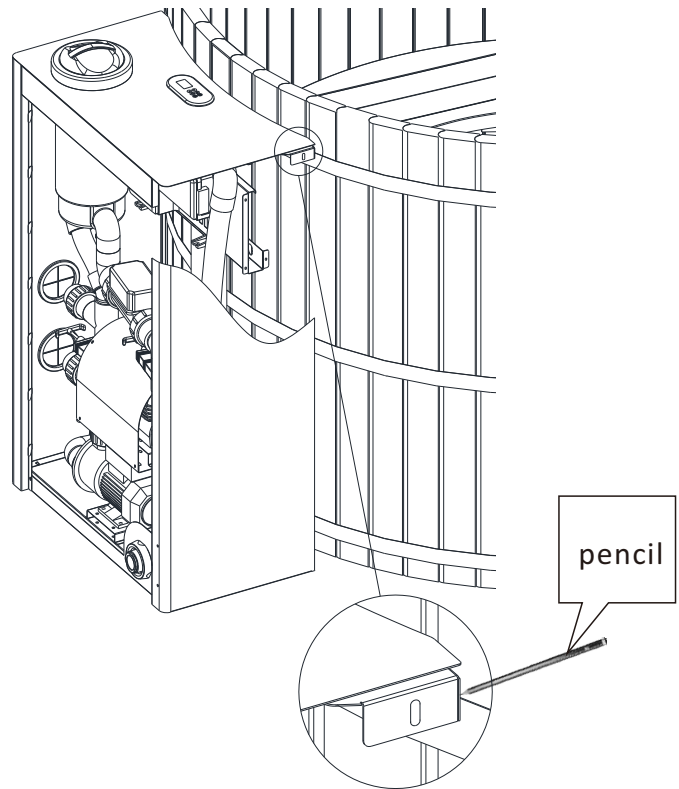

4

Remove the system cabinet

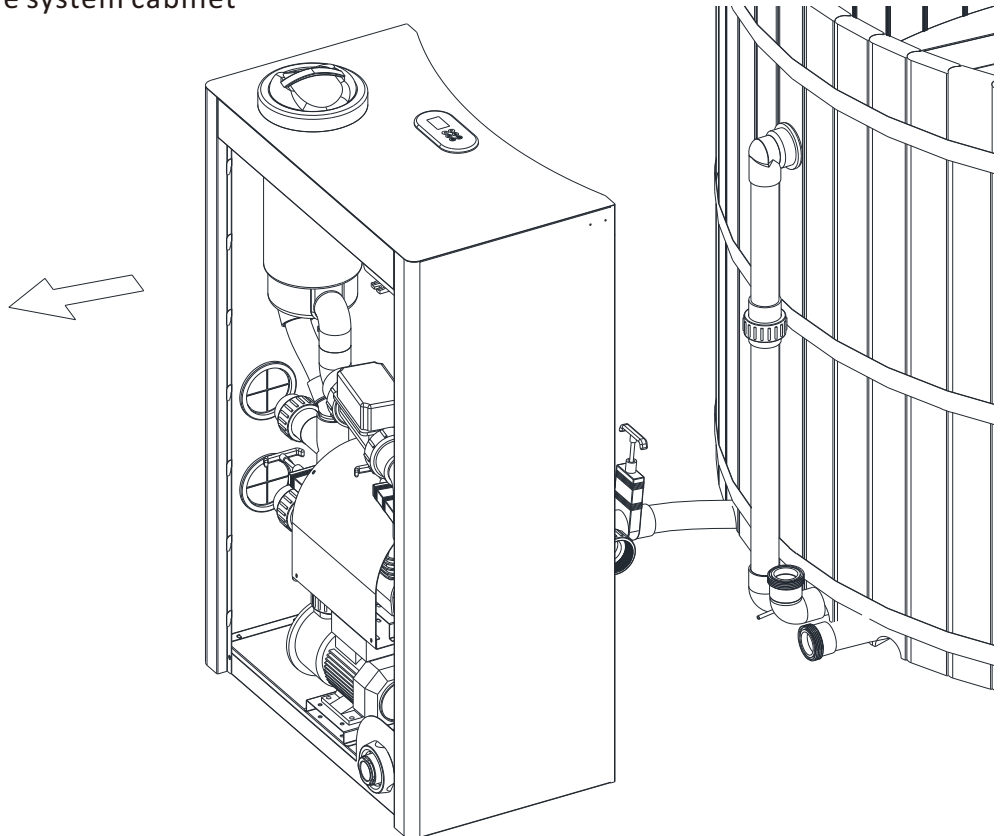

5 Install the bracket to the hot tub with screws.

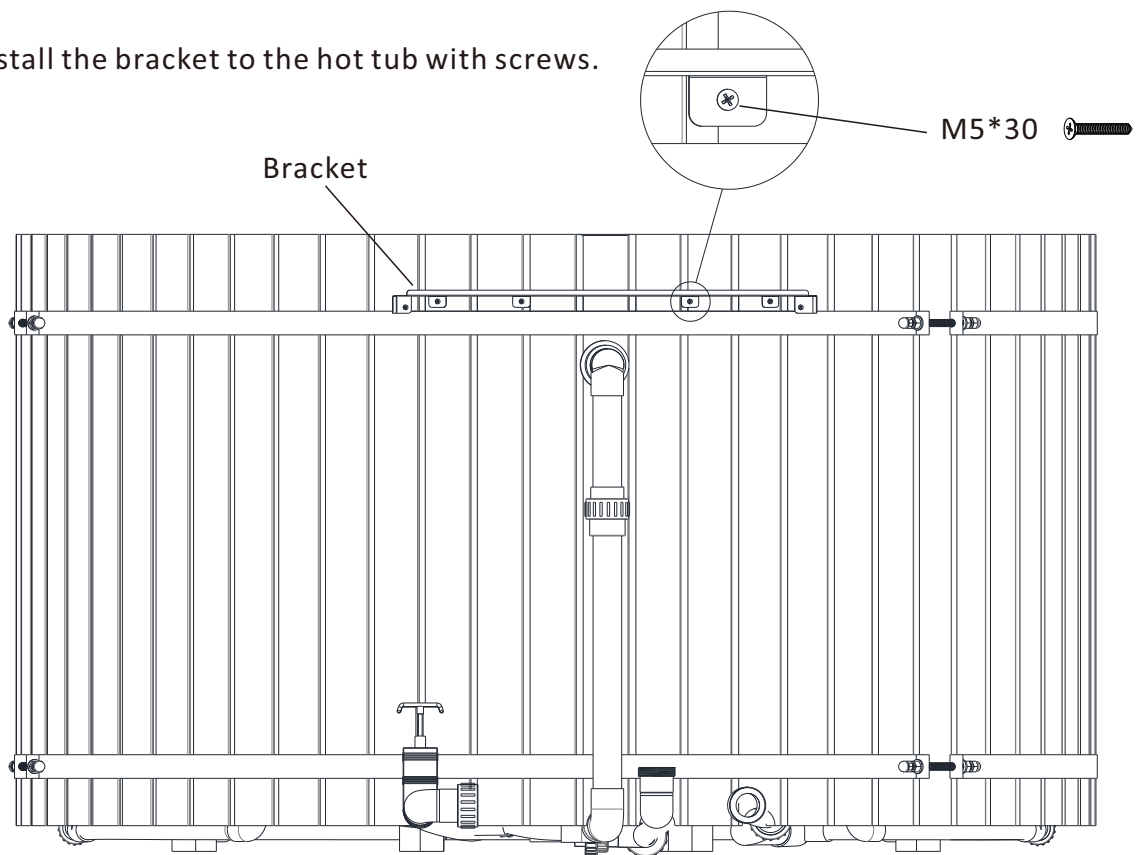

6

Connect the system cabinet and pipes of the hot tub. Don't forget the rubber sealing gasket (o-ring), or it will leak. Make sure the connections are tight

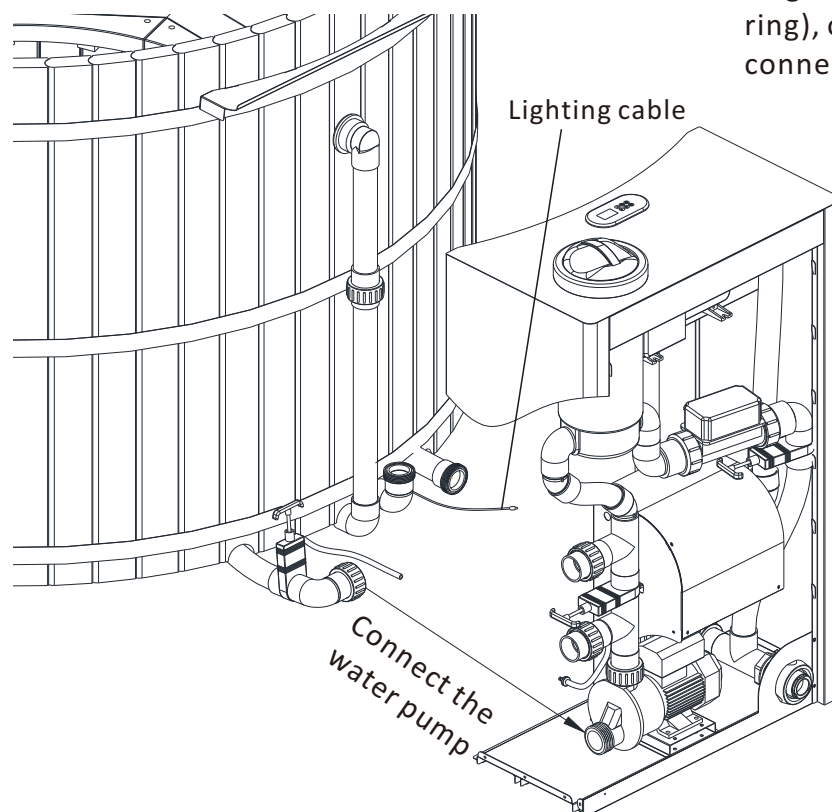



7

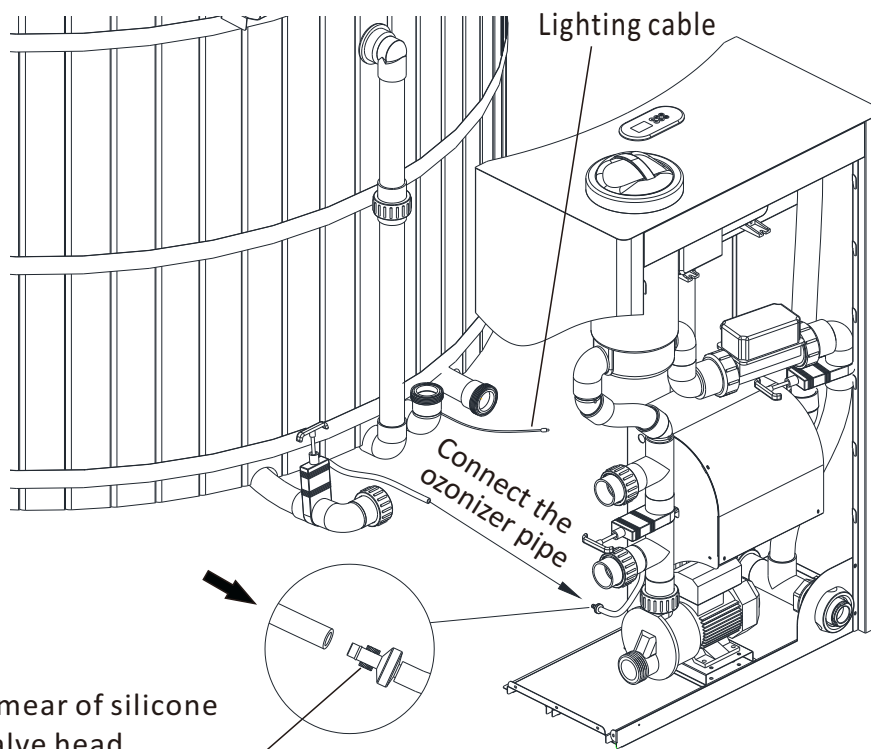

Apply a small smear of silicone on the check valve head, then insert the clear pipe of the ozonizer

8

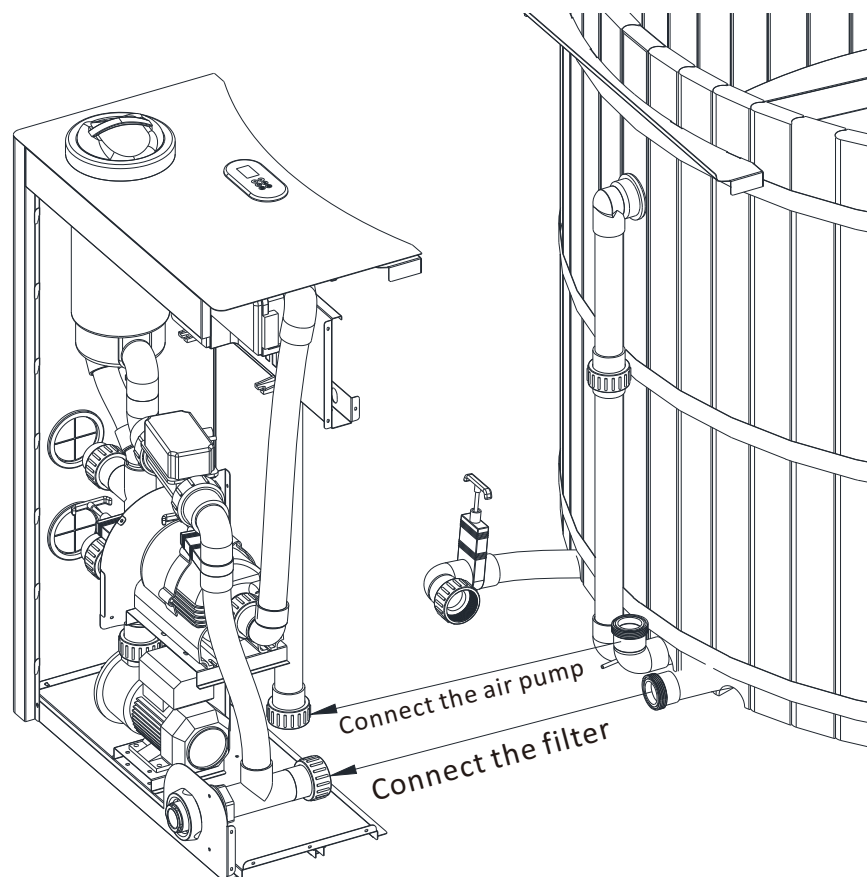

9

controller

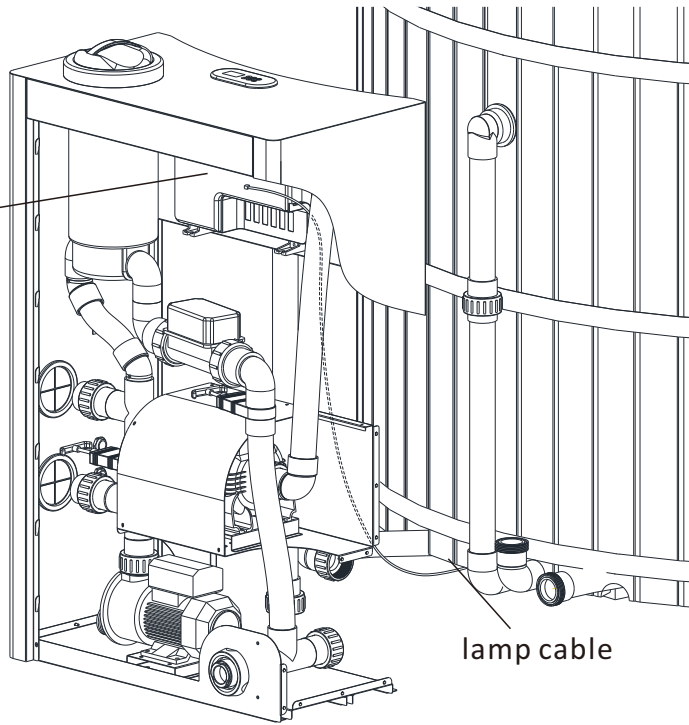

lamp cable

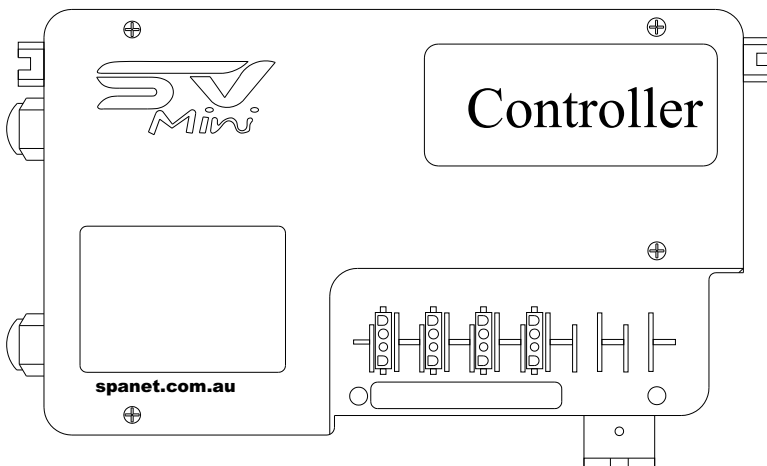

Feed the lamp cable up and through the back of the system cabinet and into the controller box by removing the faceplate. Use the provided gland on the side of the box to ensure the cable is secured safely. Plug the lamp cable into the marked 'LIGHT' port.

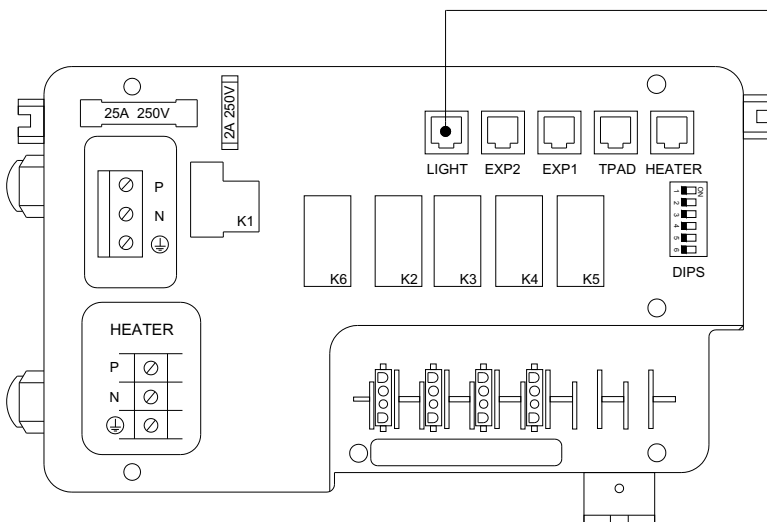

Lamp terminal

10

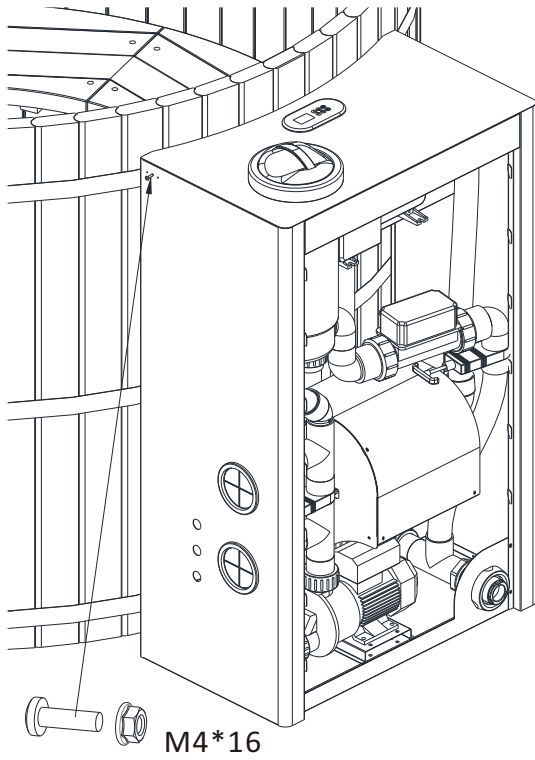

M4\*16

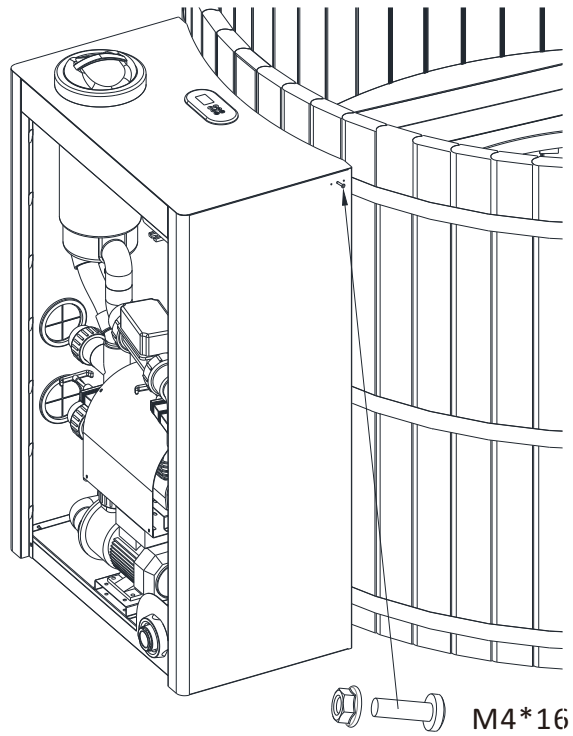

M4\*16

11

Don't rush to assemble the cedar skirts. When all other components are assembled and the spa has been tested, you can then assemble the cedar skirts.

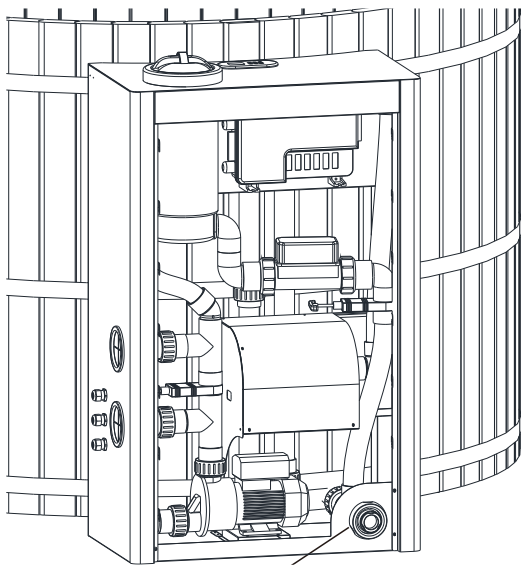

Drain valve

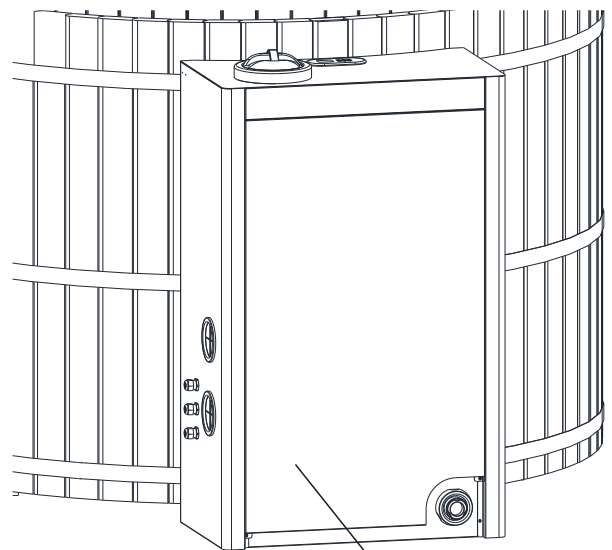

Removable service panel

◇Wood fire heater installation(Optional)

①

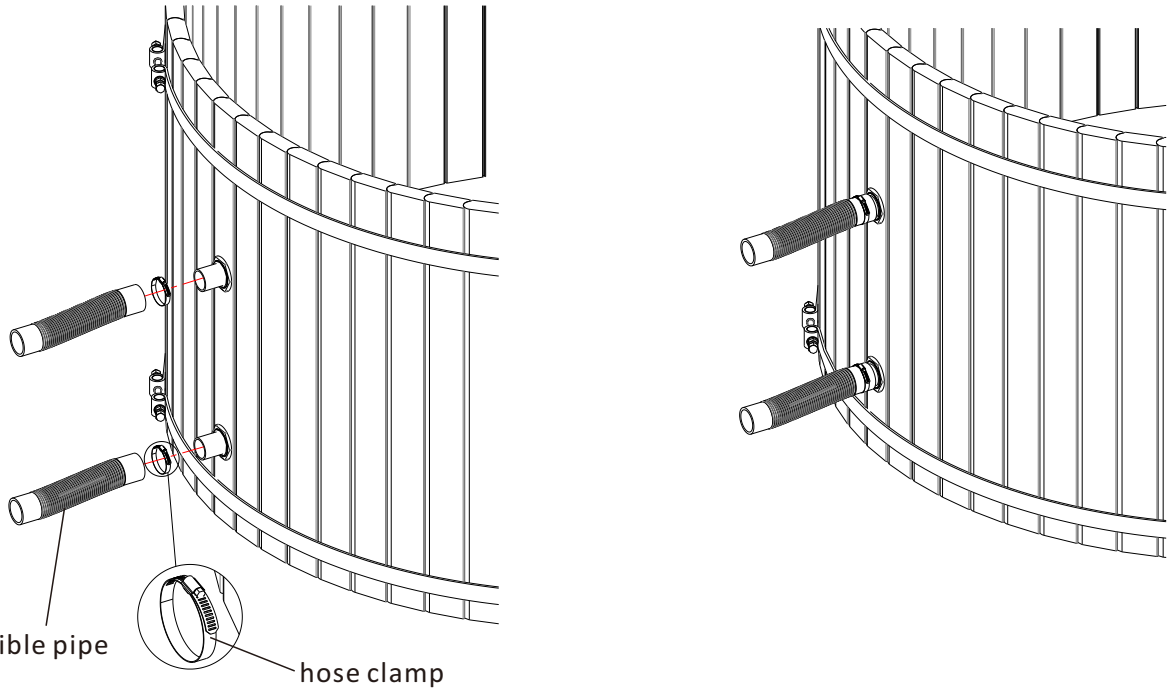

②

Open the oven door, take the chimney top out of the combustion chamber and then start the heater installation

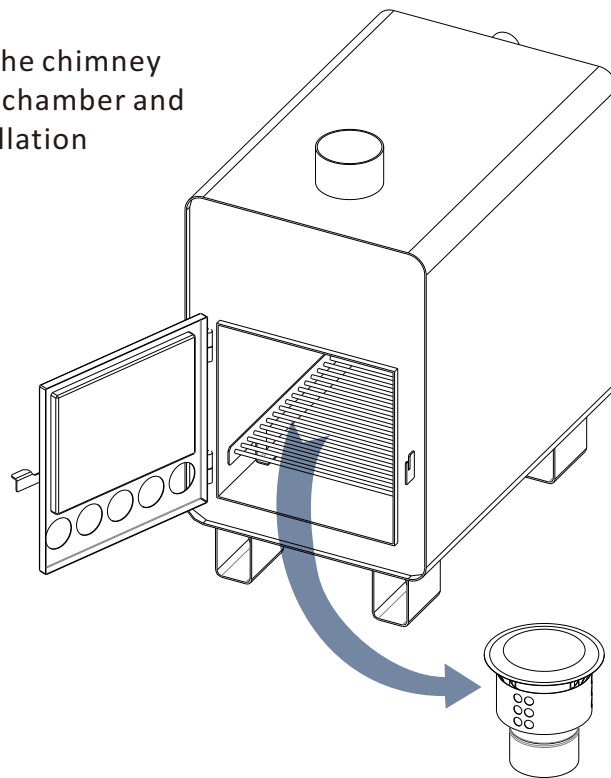

3

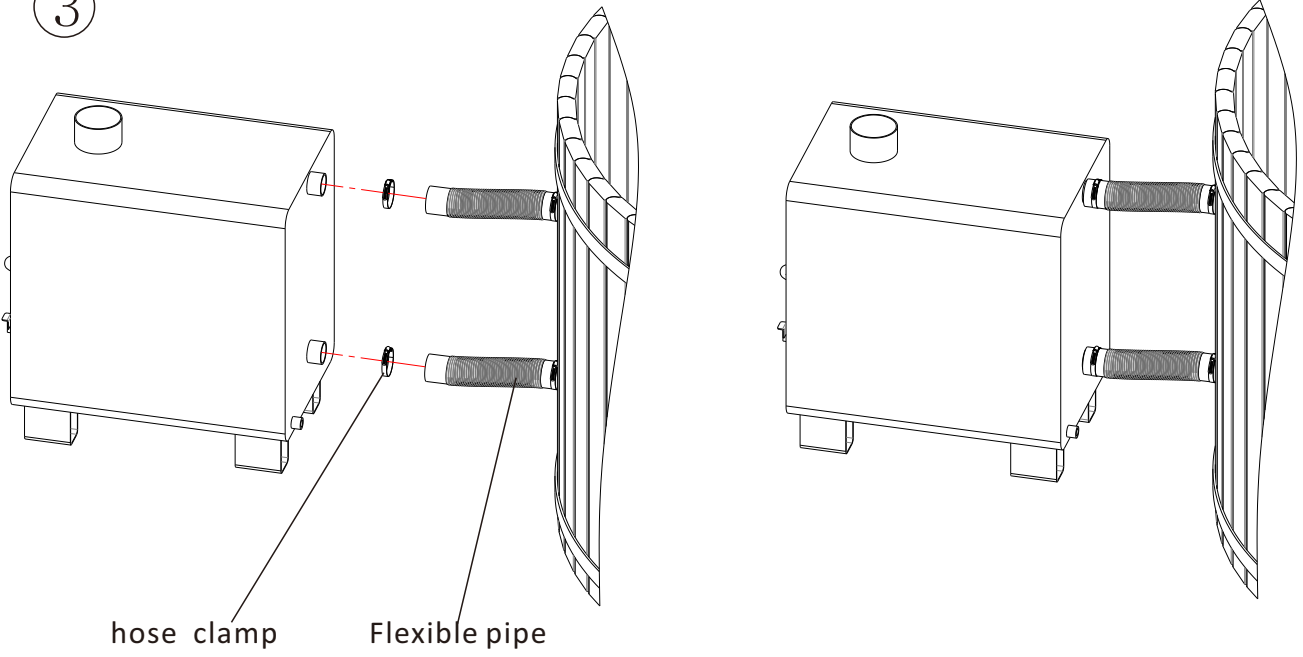

Note: it is critical the heater is set up so the pipes are level

4

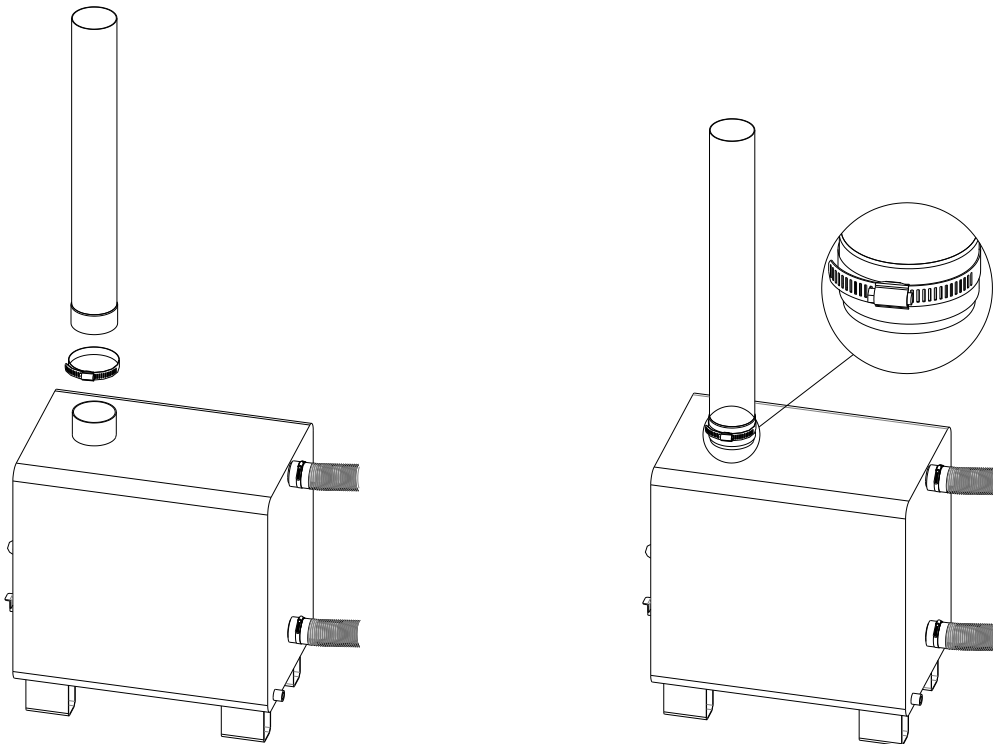

5



Note: The edge of the chimney and the chimney top is very sharp. Please wear gloves during installation to prevent injury. (rivets or screws should be used to join the sections of the flue together.)

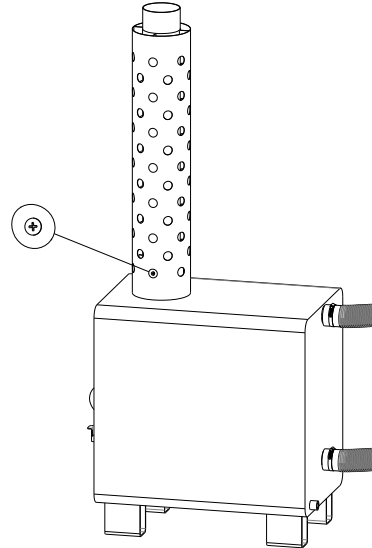
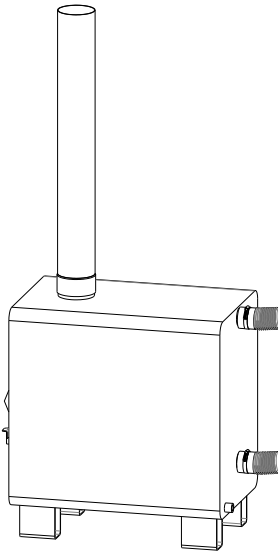

6

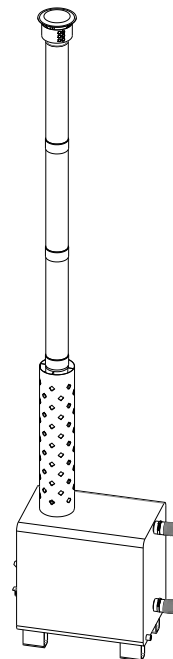
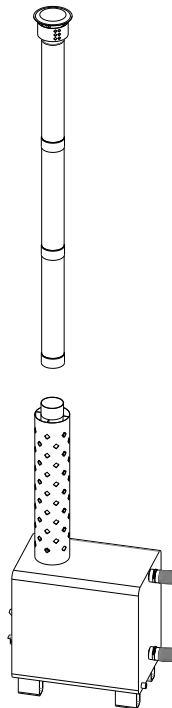
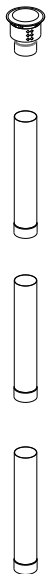

## ◇ Ladder assembly

①

The hot tub ladder with a height of 3.5 feet has 3 steps, and the hot tub ladder with a height of 4 feet has 4 steps. Assemble the ladder as shown below:

Note that the curved top step cannot be installed yet.

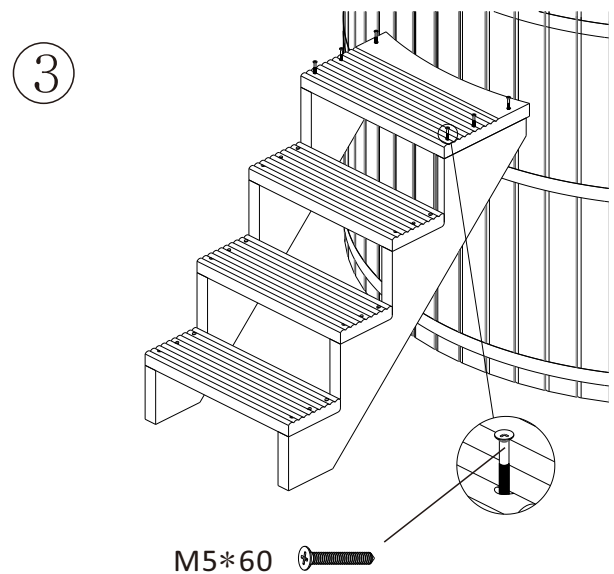
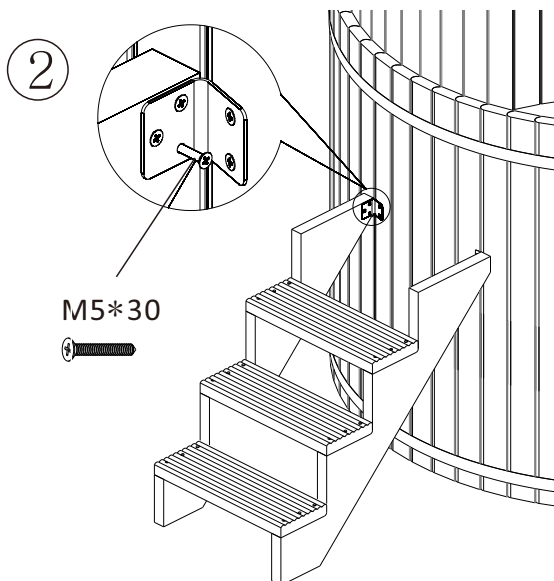
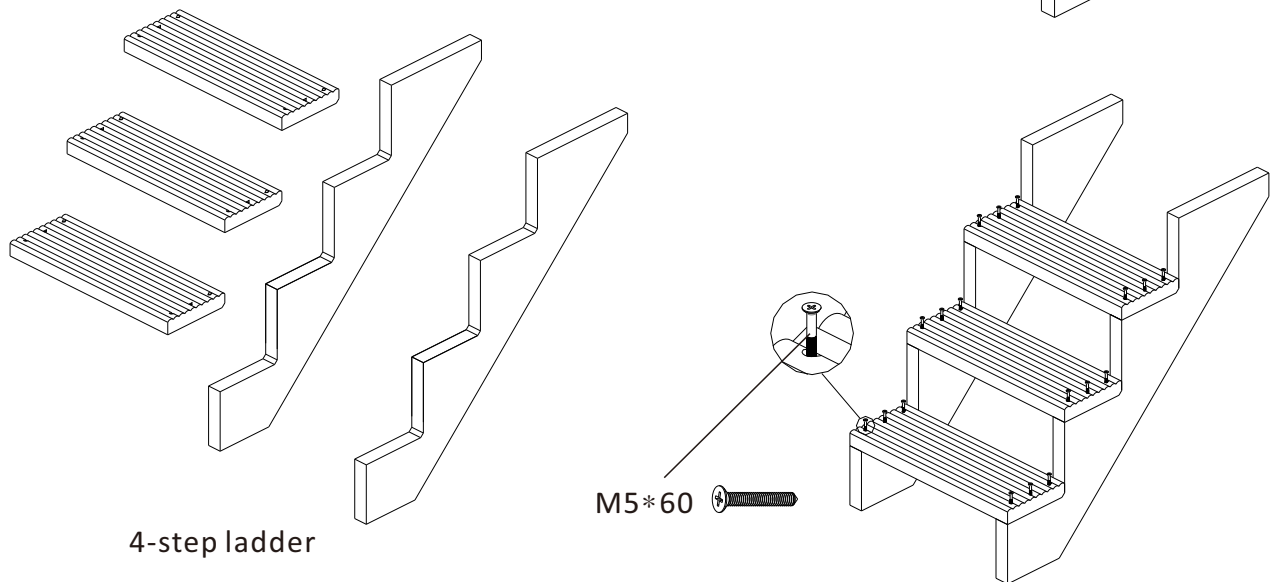
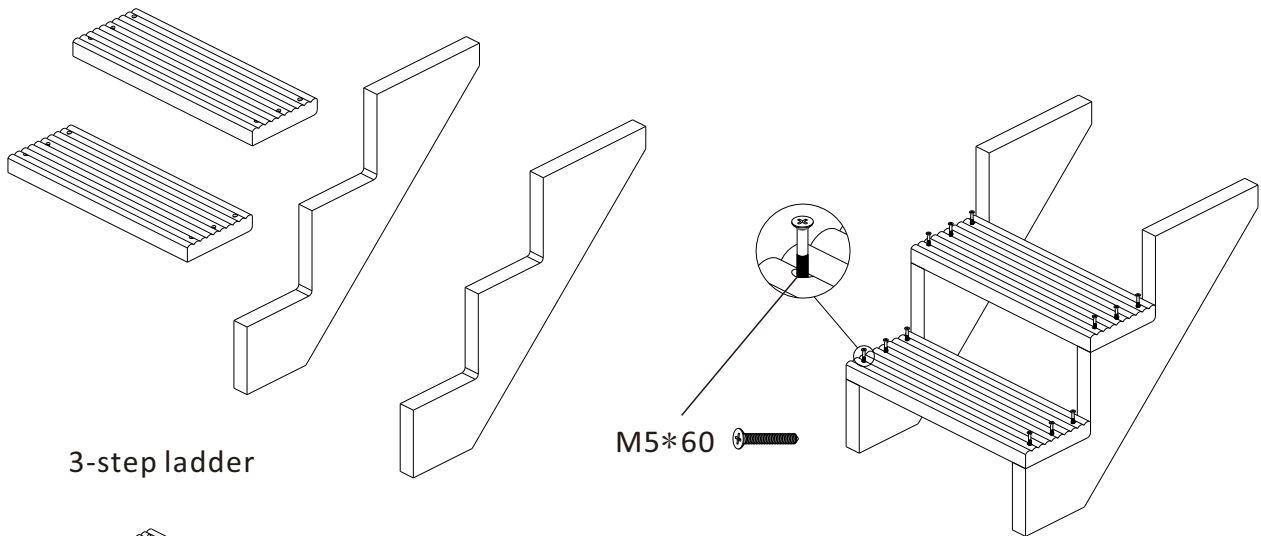

## ◇ Bench assembly

①

Join the bench seats and legs in the Hot Tub. Pay attention ensuring to align the panel with screw holes in the legs. Fix it with M6\*60 screw

but don't tighten until all are in place..

Specificati on of Hot Tub	Amount of bench panel (pcs)	Amount of bench feet (pcs)
5feet	9	9
6feet	8	8
7feet	9	9

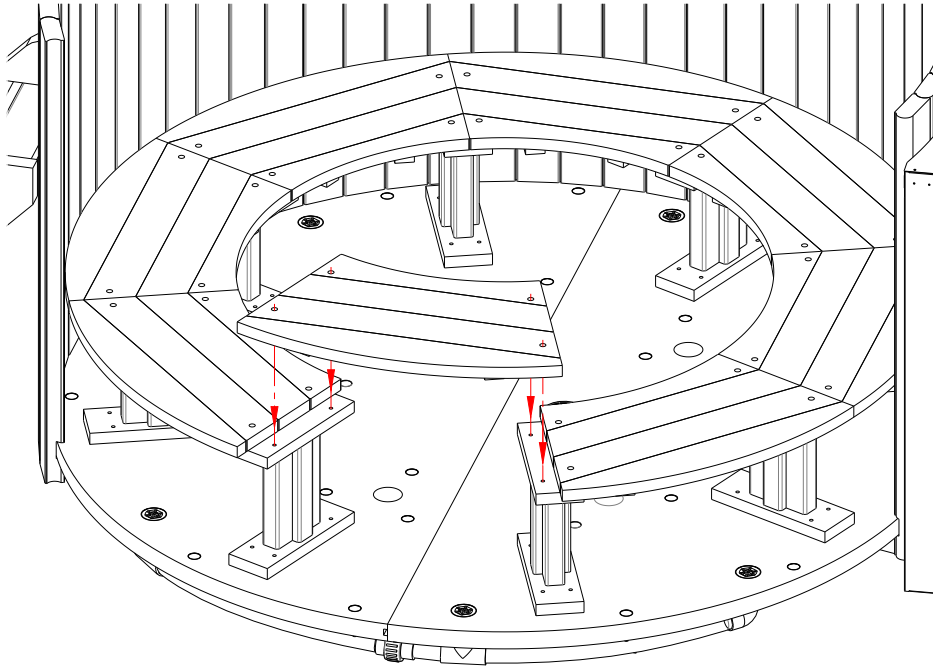

②

Place the bench feet on the base and mark the position with a pencil.

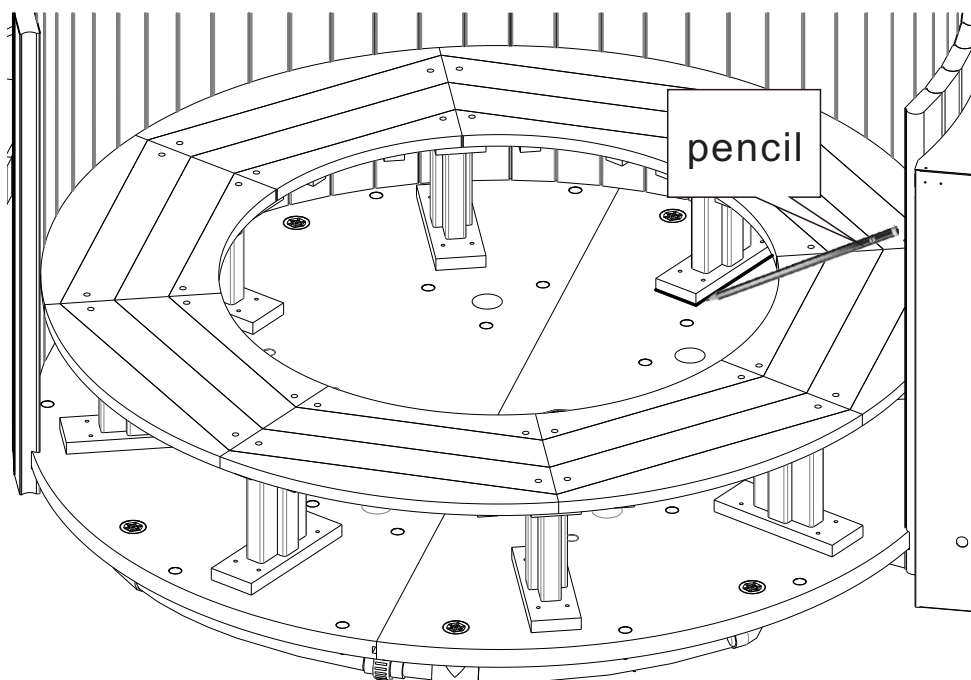



3

Move the bench panel away, and fix the feet in the base with M5\*50 screw.  
Note: You can install them with the seat tops bolted in place.

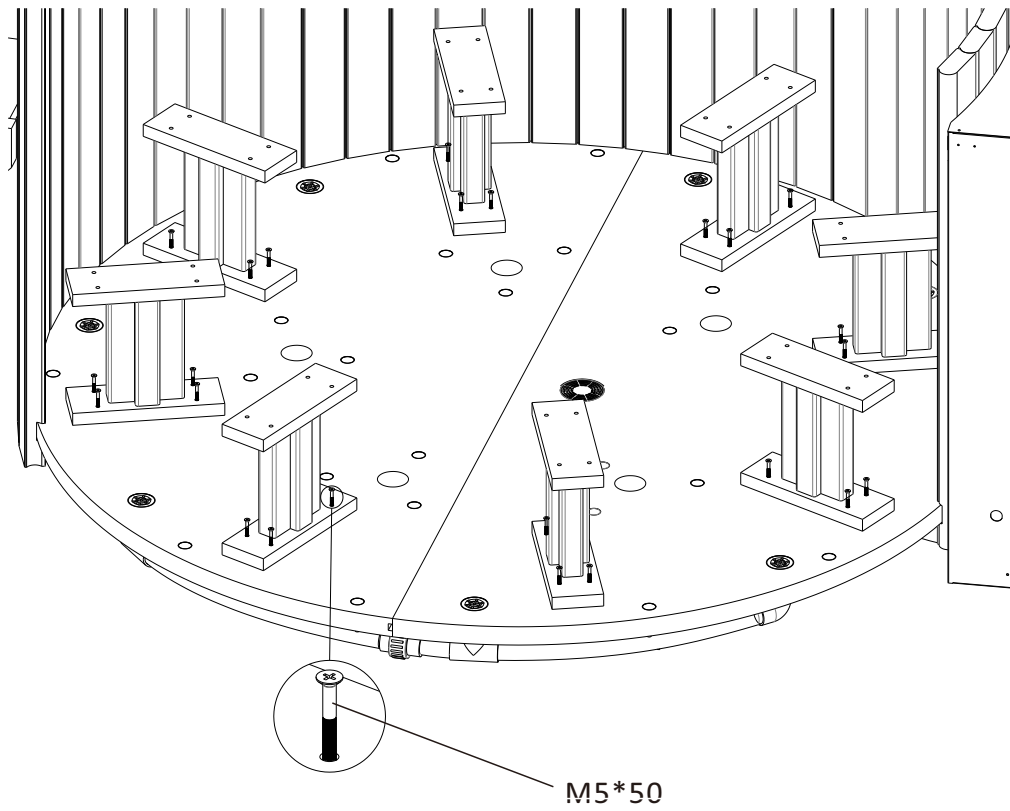

4

Fix the panel to bench feet with M6\*60 screw.

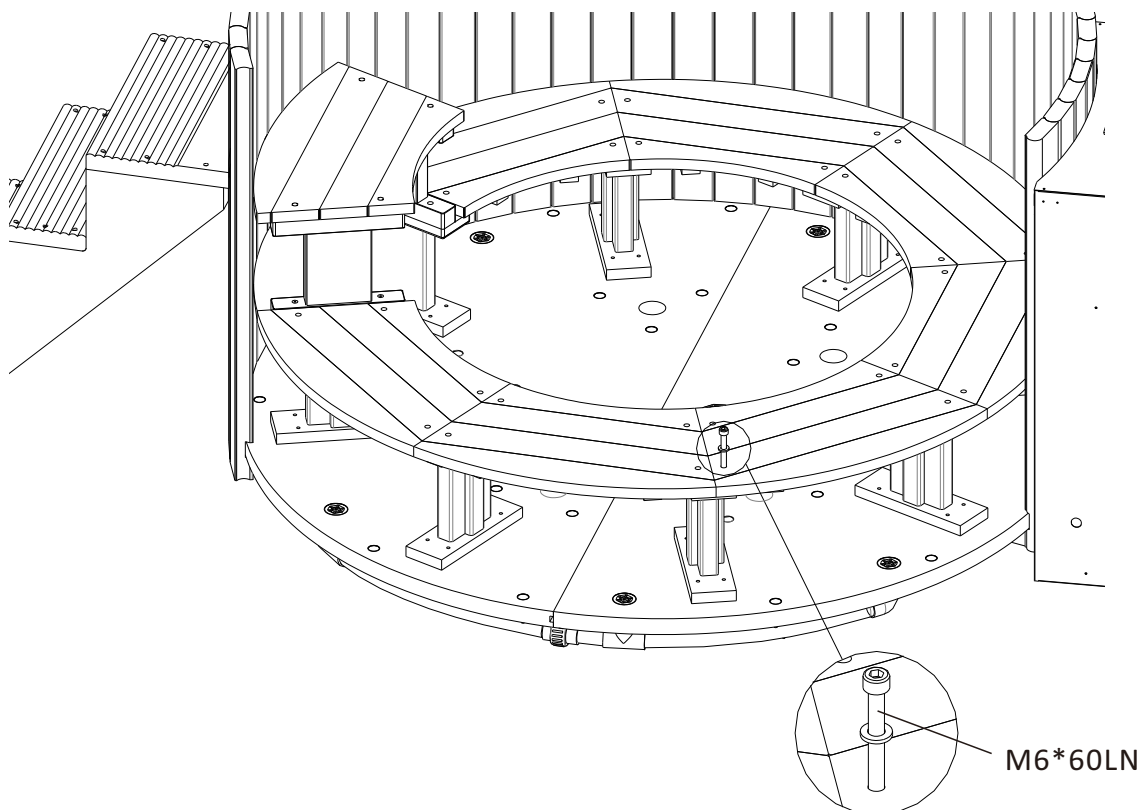

### ◇ Insulation cover assembly

Install the insulation cover as shown below.

Note: Please lock the clips when the Hot Tub is not in use to prevent debris from falling in the water.

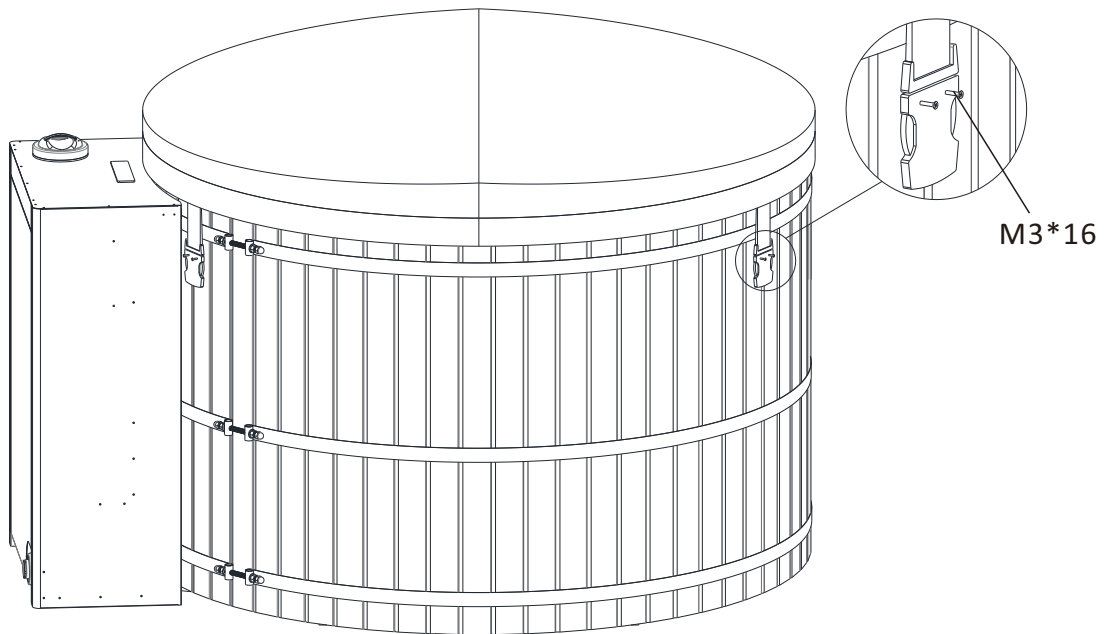

### ◇ Cedar skirts Installation

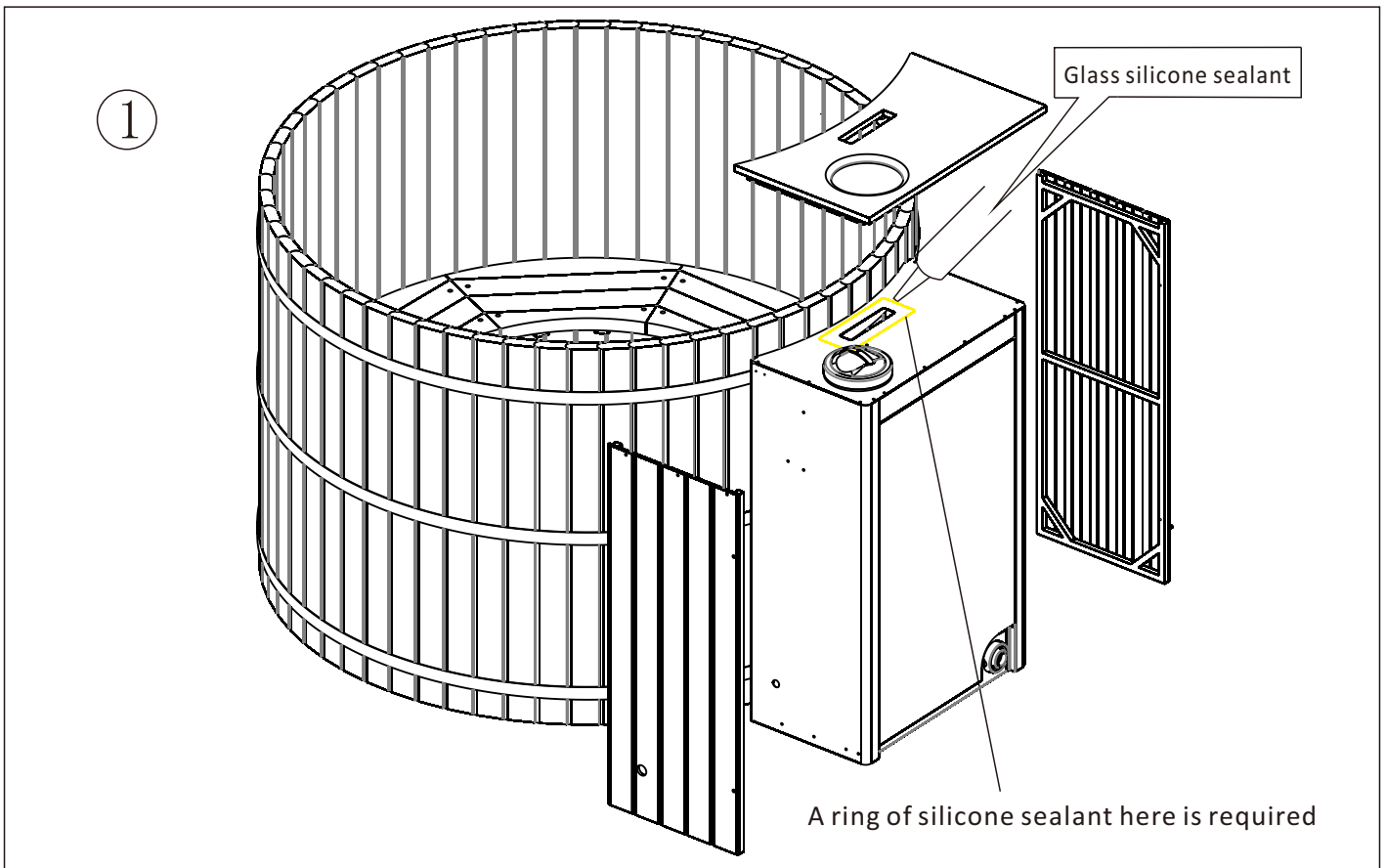

2

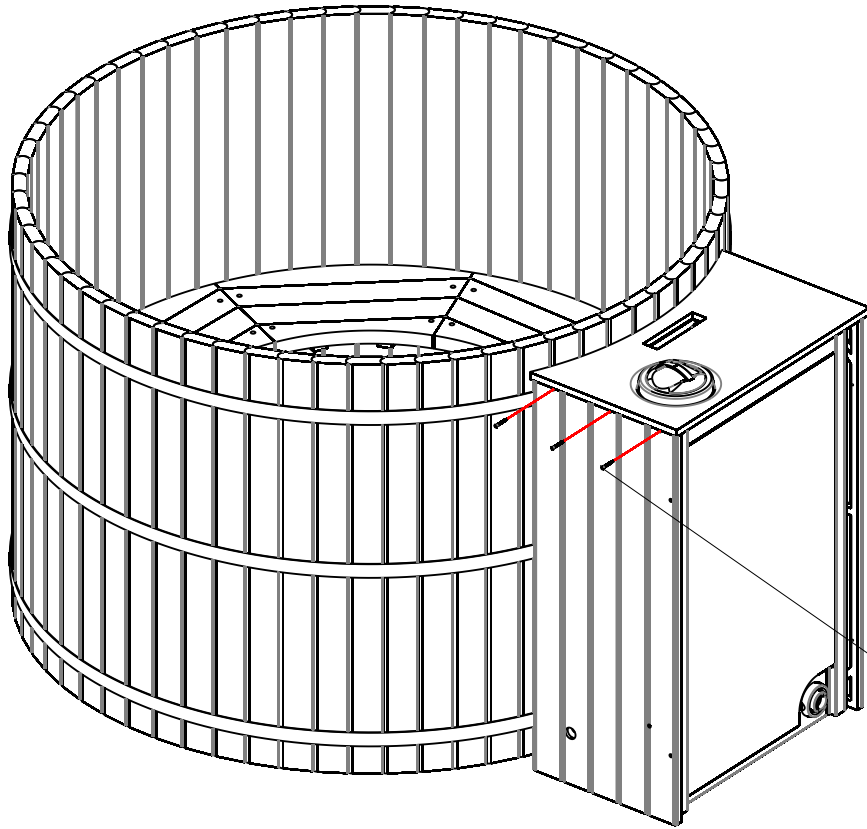

M4\*25  
3 PCS

3

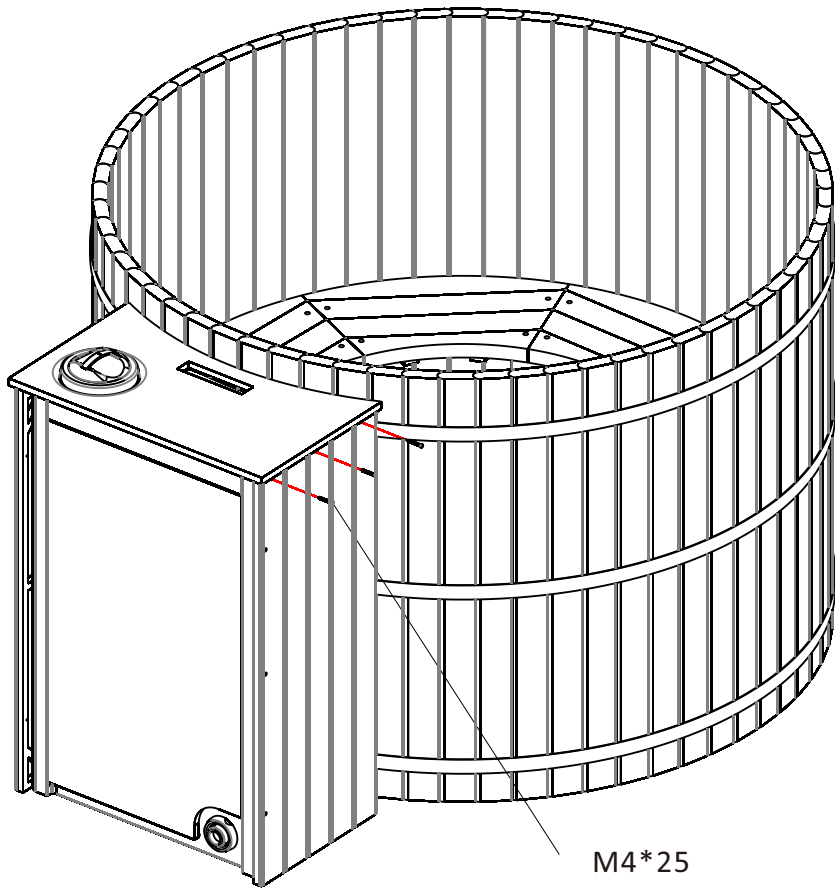

M4\*25  
3 PCS

④

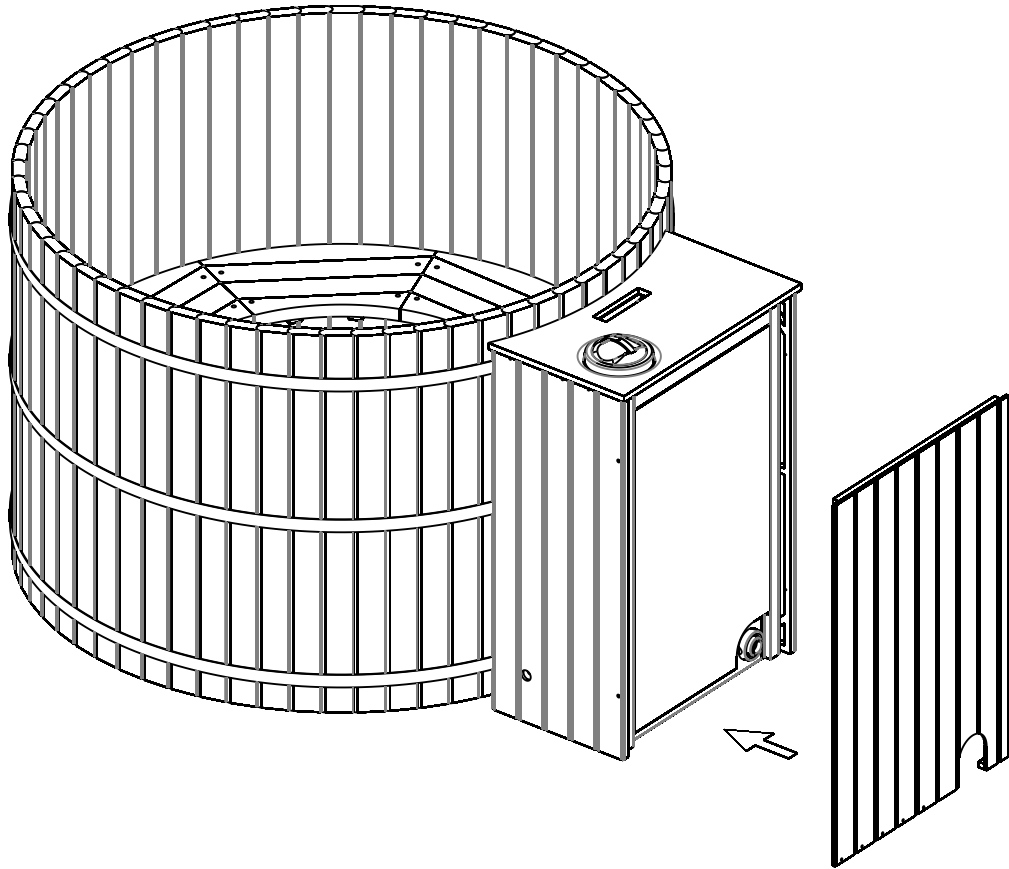

⑤

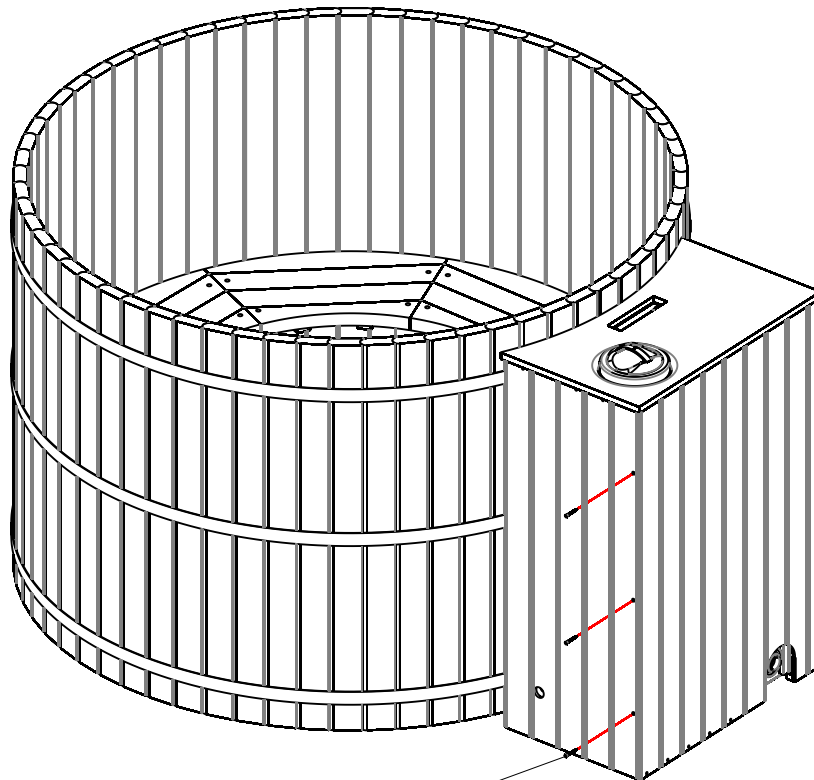

M4\*40  
3 PCS

6

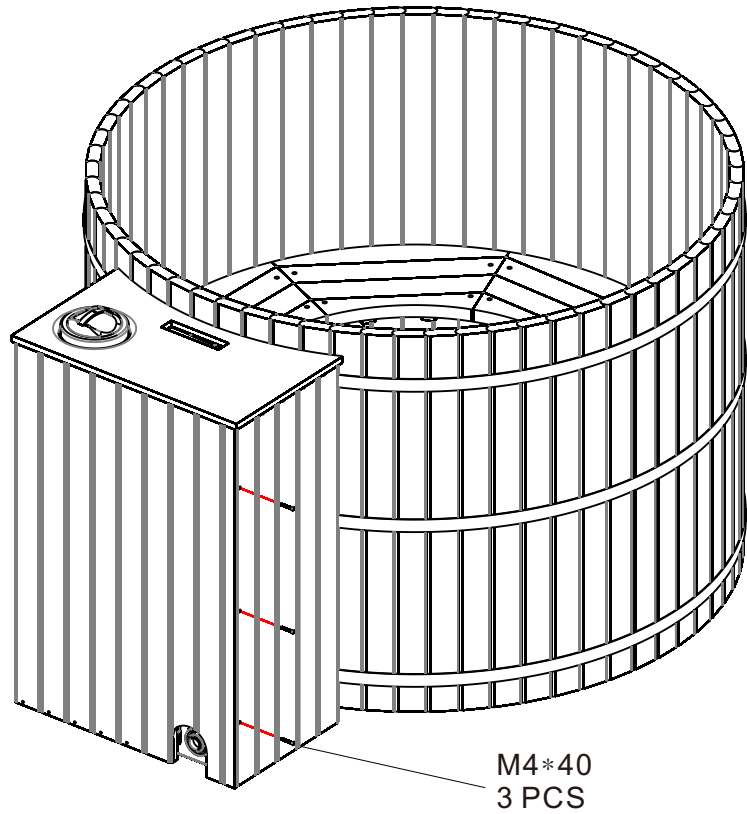

M4\*40  
3 PCS

7

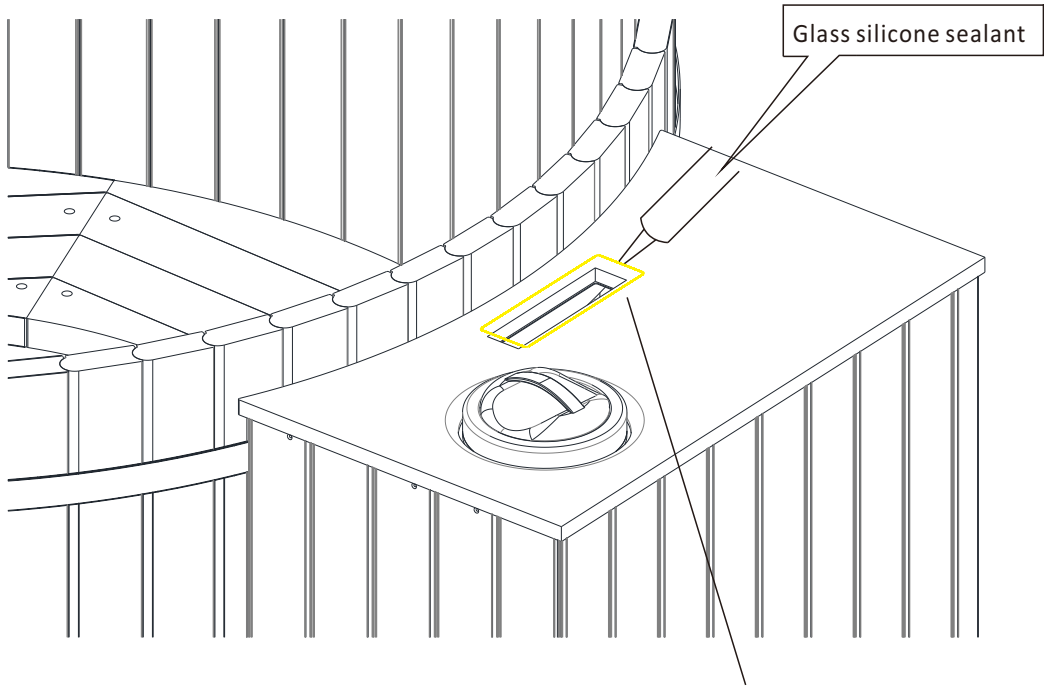

Glass silicone sealant

A ring of silicone sealant here is required

8

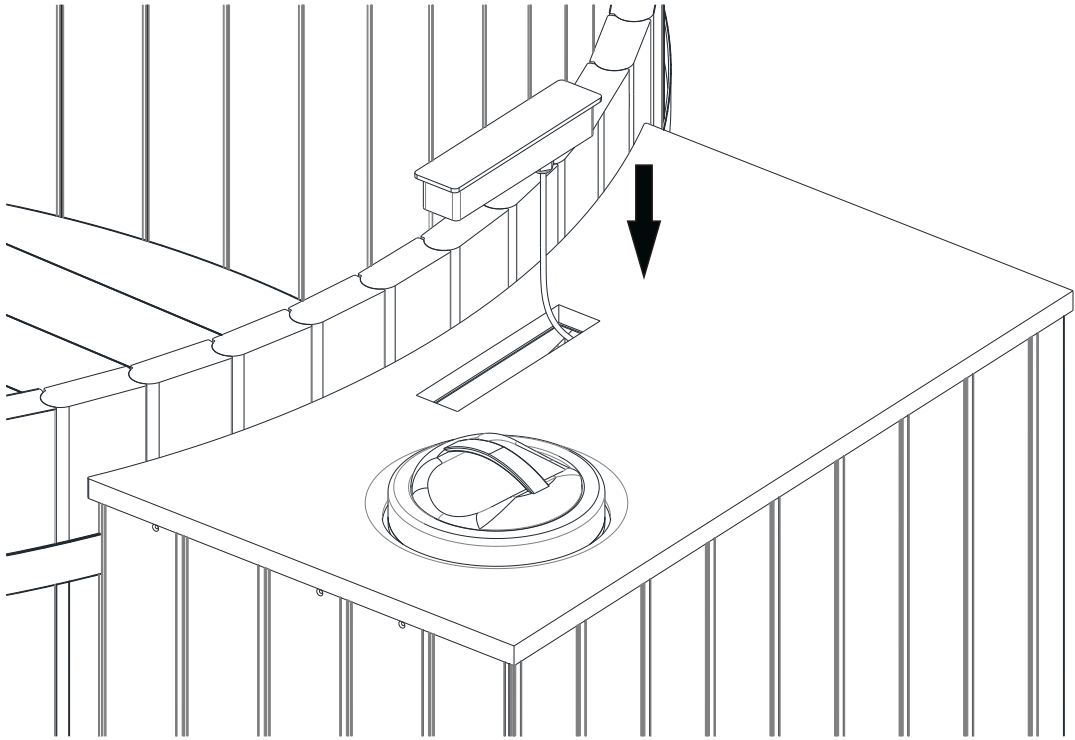

9

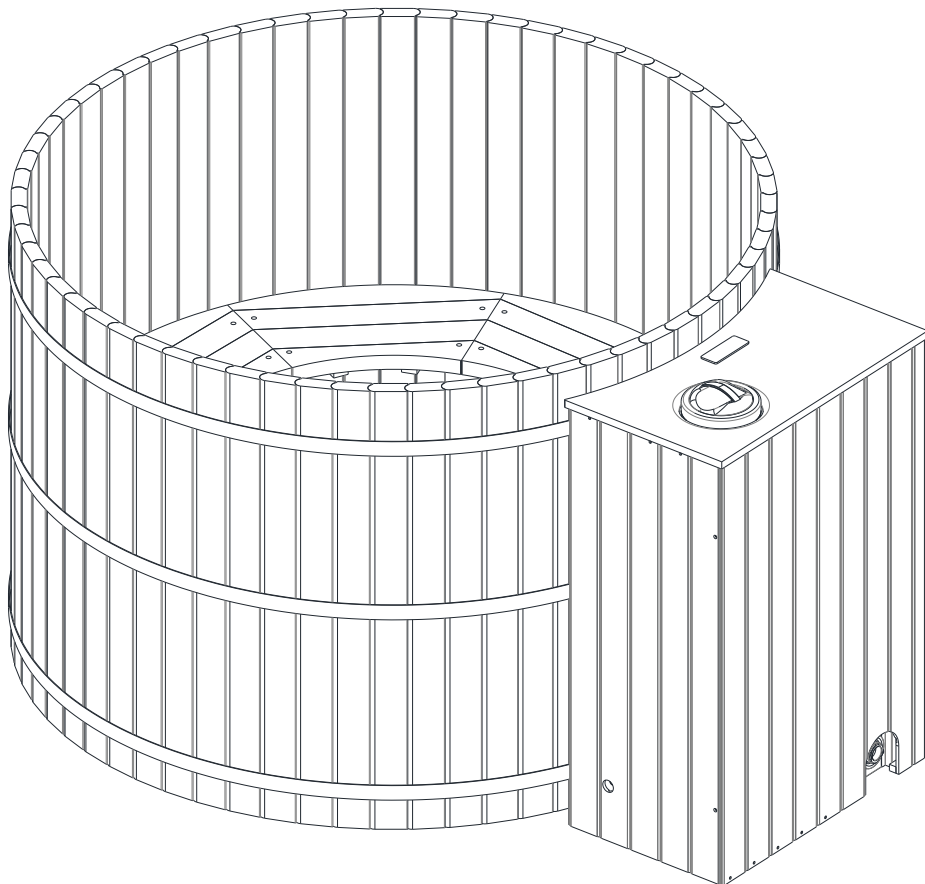

# Installation completion

Note: do not fill with water until 72 hours after completion to allow silicons to cure.

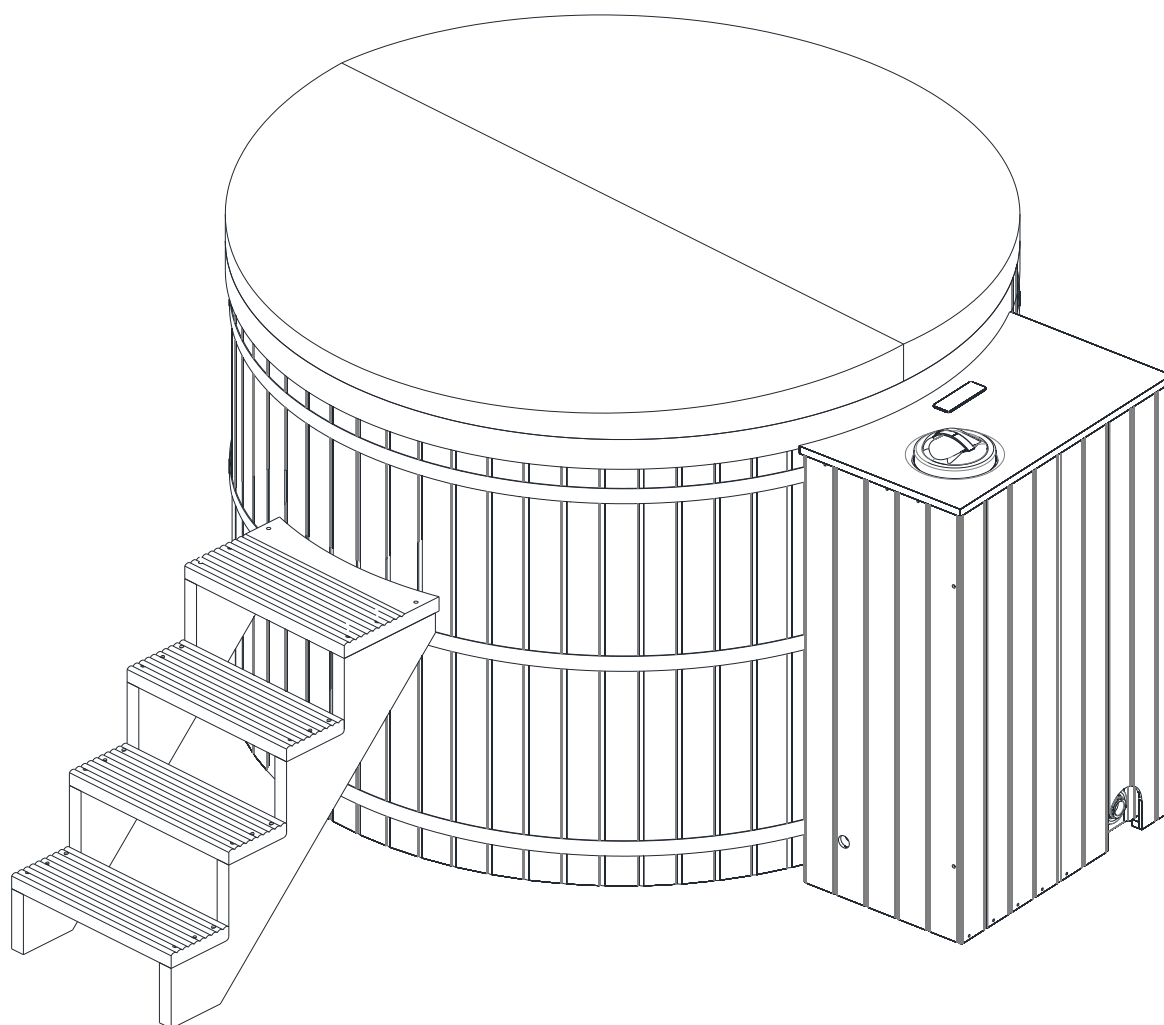

## ◆ Heat pump connection (Option)

- ① Remove the front cedar skirt

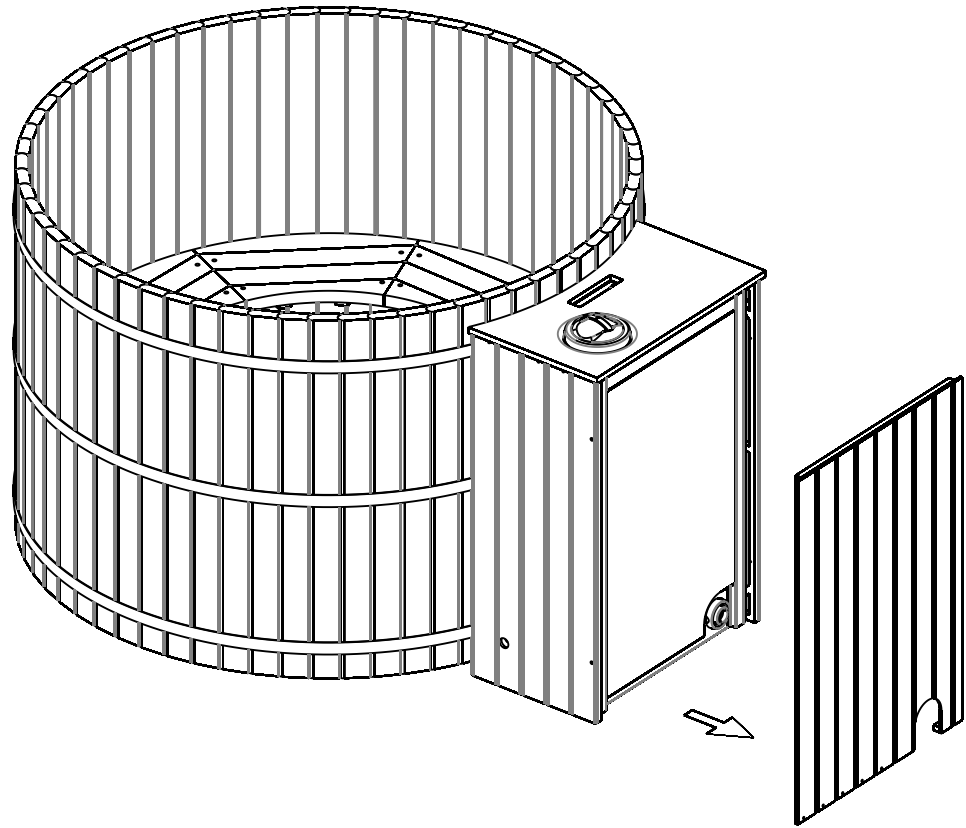

- ② Remove the front panel of system box

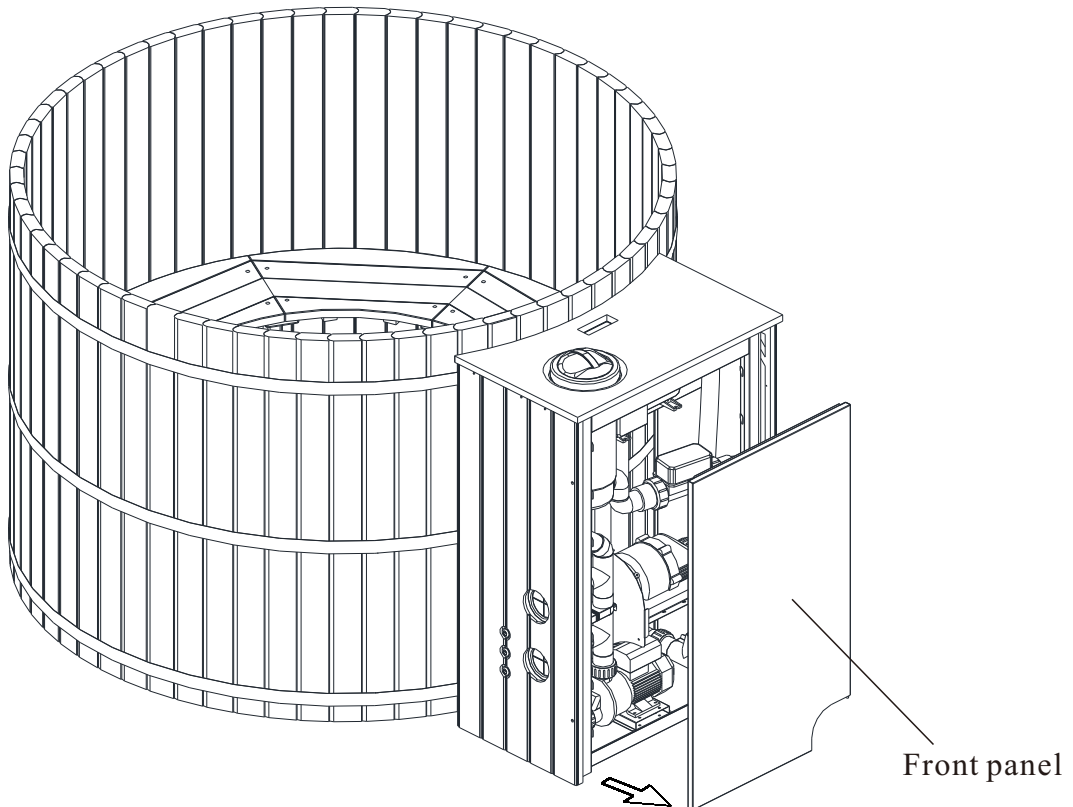



3

Use craft knife to open the hole of left side cedar skirt

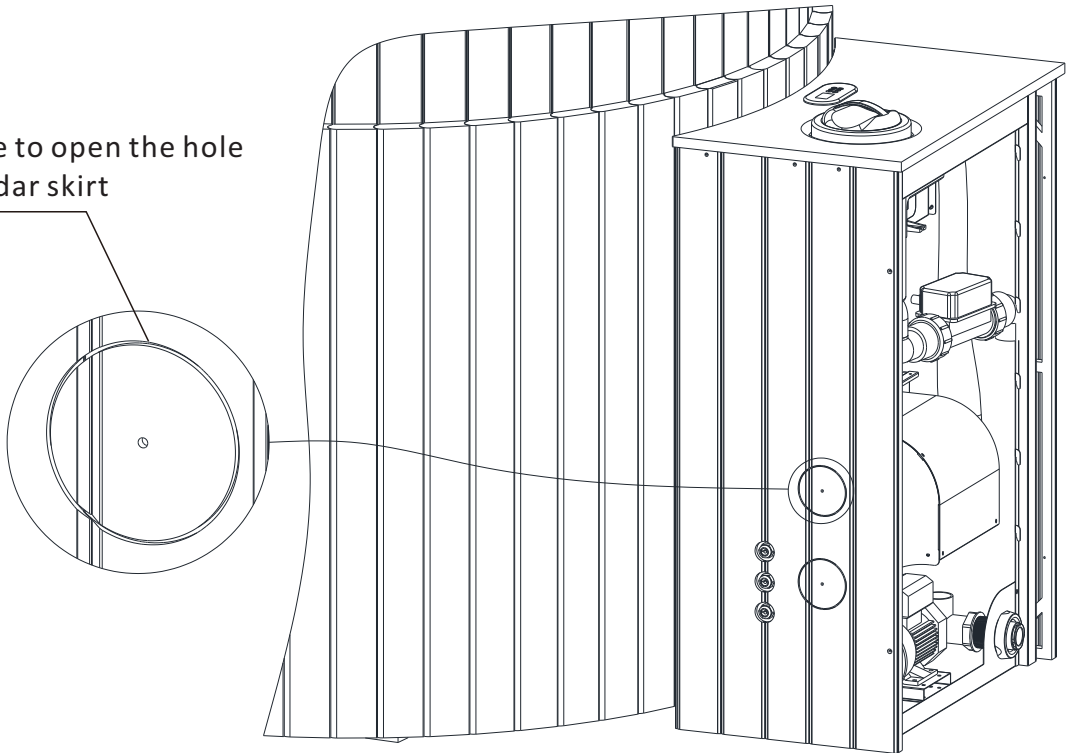

4

Use scissors or a craft knife to cut the rubber grommets into slits to allow for piping to pass through the inlet/outlet holes.

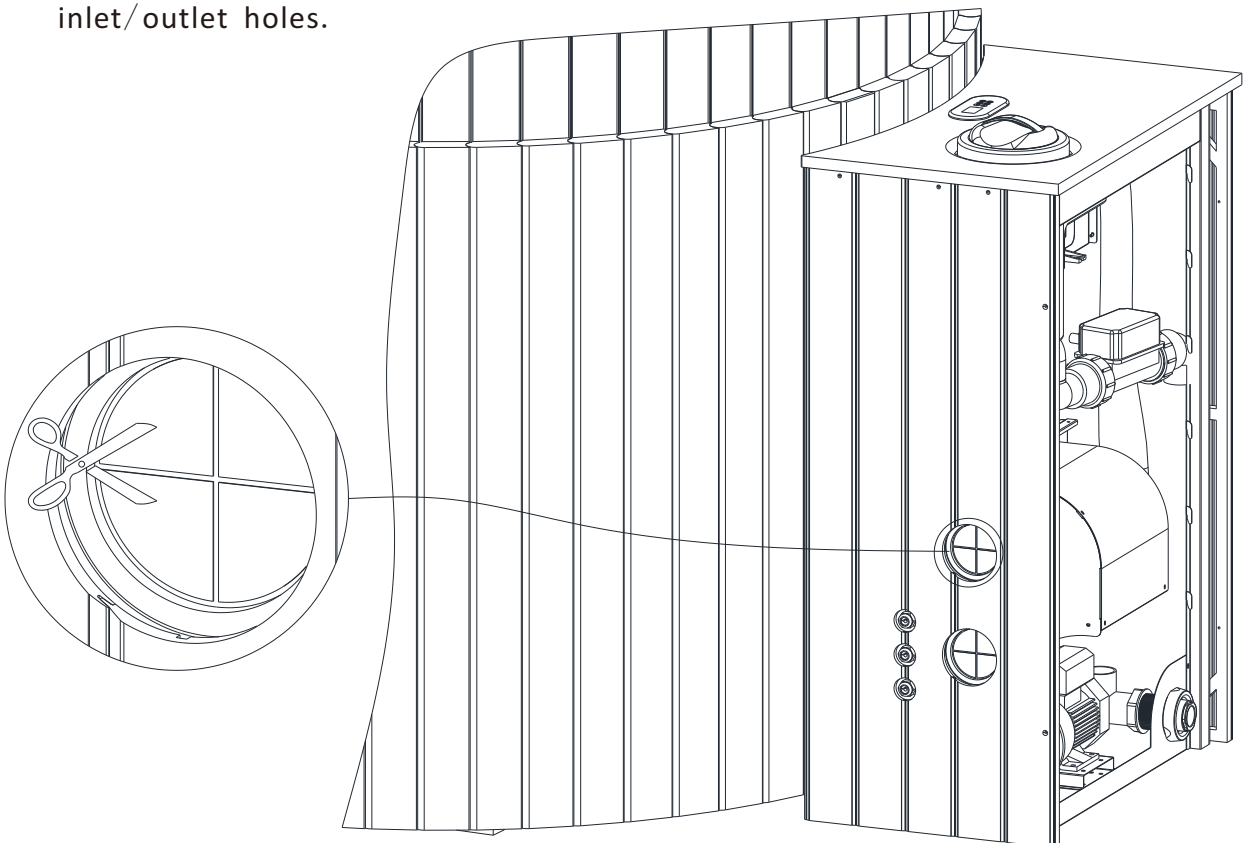

- 5 Position the heat pump, and connect  
Dia.1.5" PVC hosepipe with suitable  
length

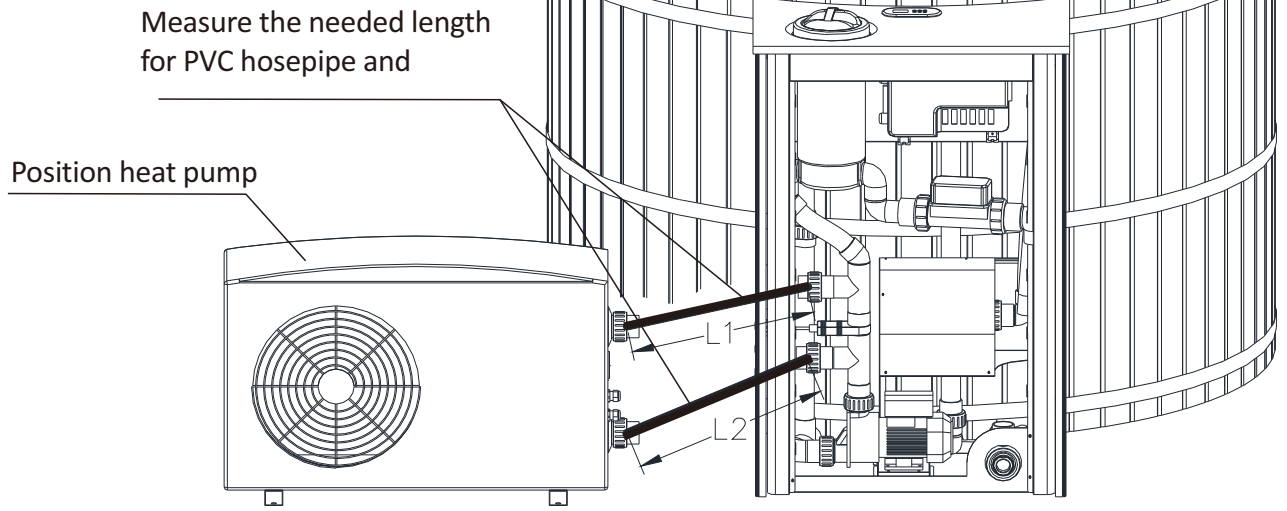

- 6 Unscrew the loose joints of system cabinet, take off the  
stopper and close the gate valve

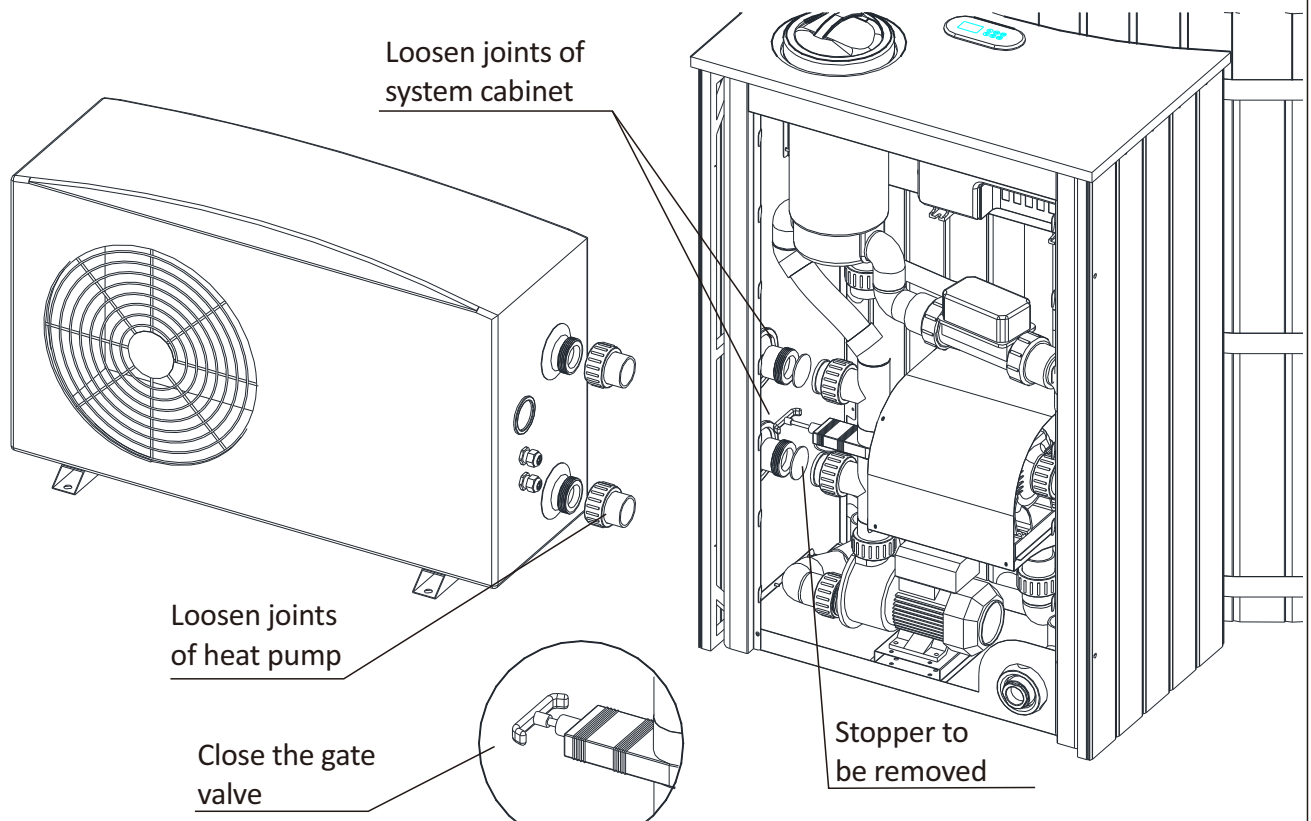

- 7 Connect the loose joints with PVC glue to both ends of dia. 1.5" PVC hosepipe

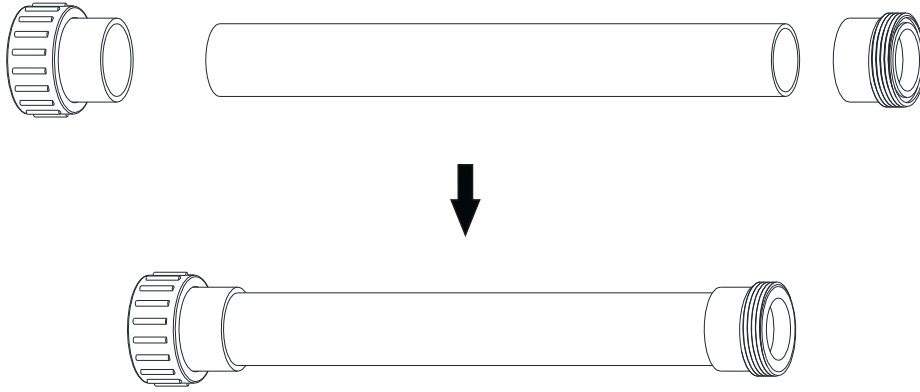

- 8 Connect PVC hosepipe to system cabinet and heat pump

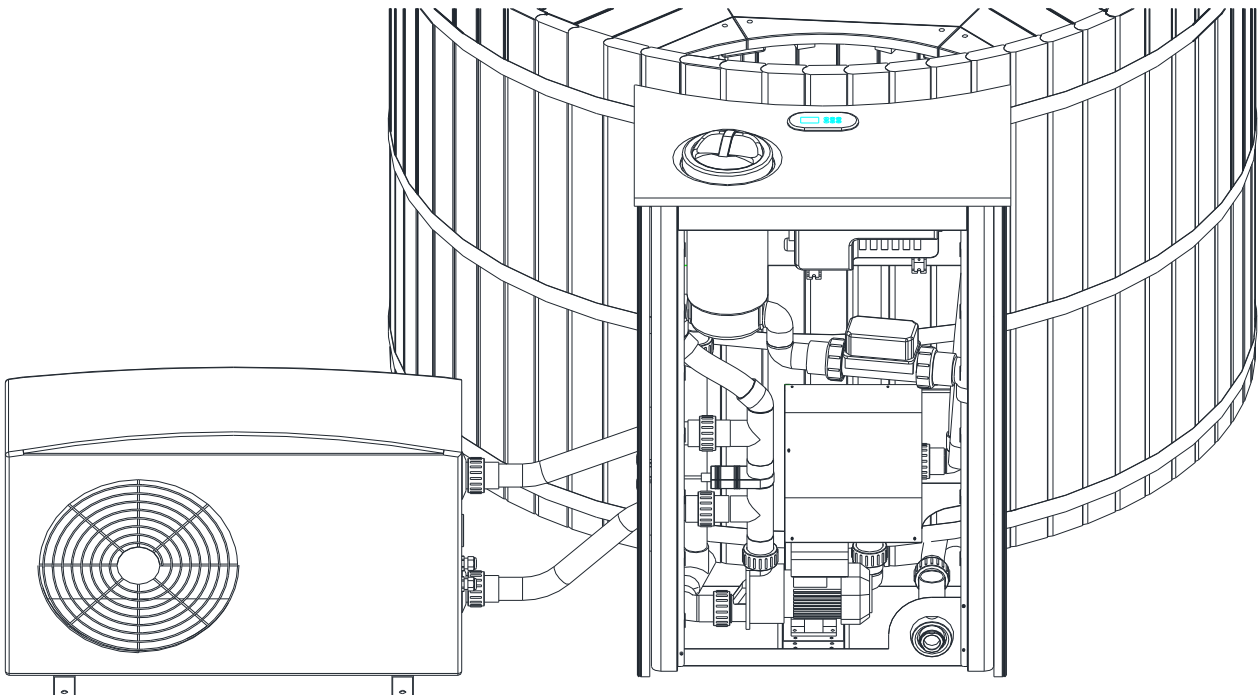

9

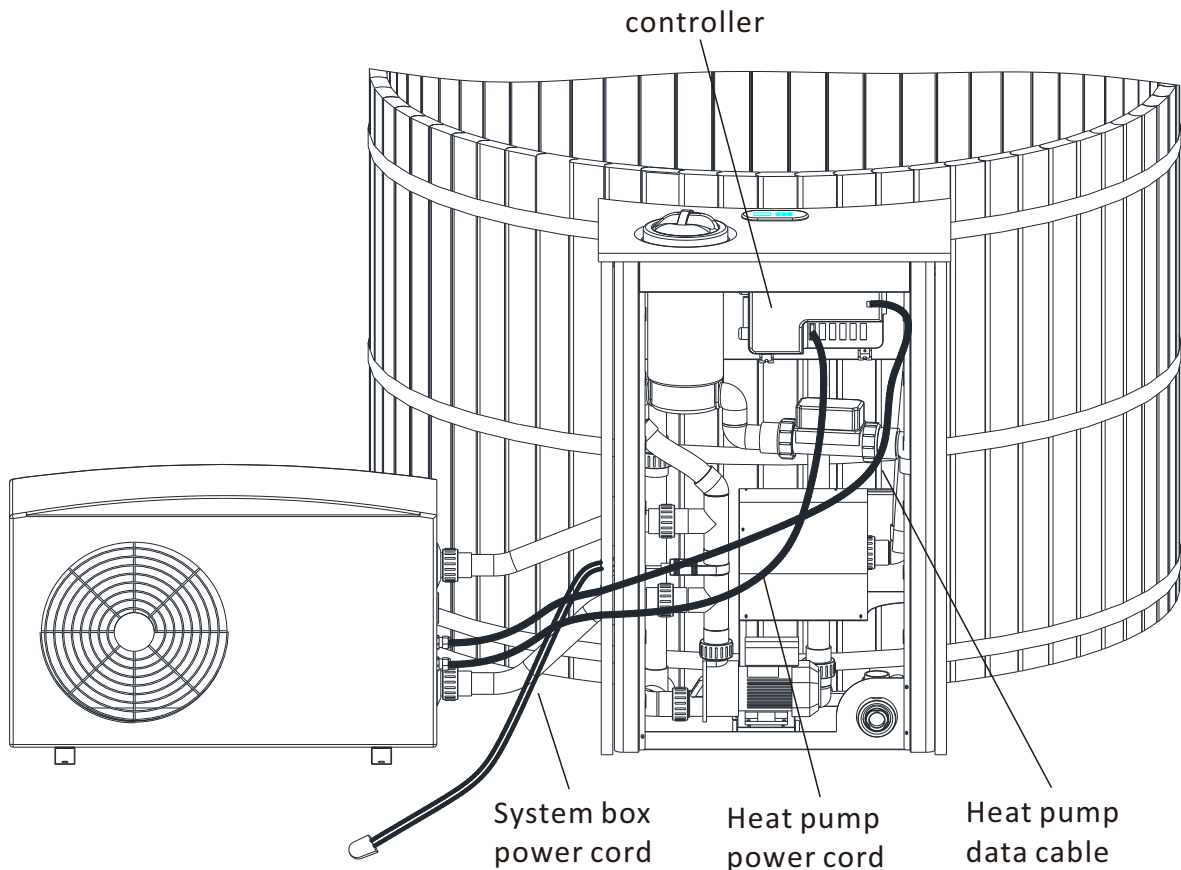

**! Connect the heat pump power cord and data cable to corresponding position on the control box through the waterproof connectors**

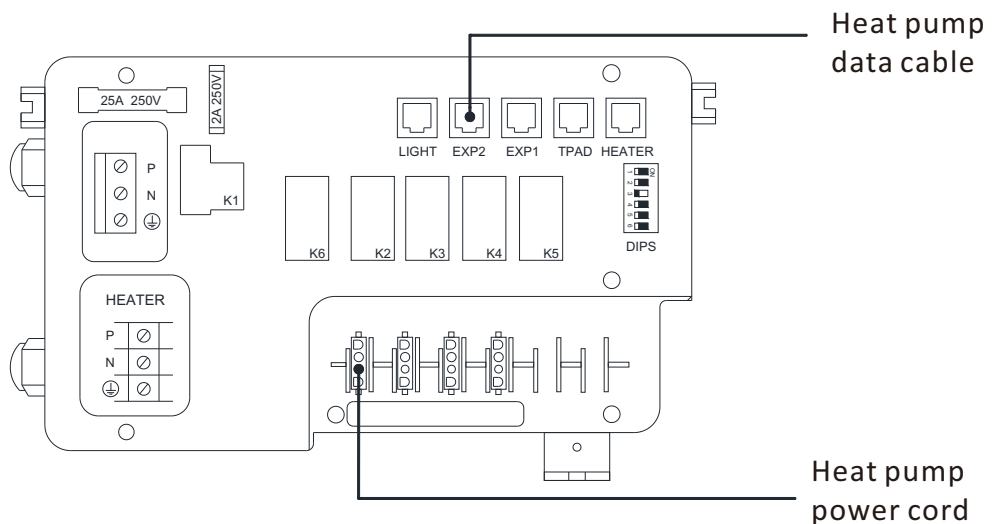

Ensure that you have not plugged in the 15amp system power cable. Remove the faceplate from the controller. Plug in the heat pump data cable and the power cord as per the diagram. Replace the controller faceplate and then place the removable service panel back onto the system box. This completes installation for heat pump.

Note: please refer to the matching instruction manual for heat pump use.

10 Reinstall the front panel of system box

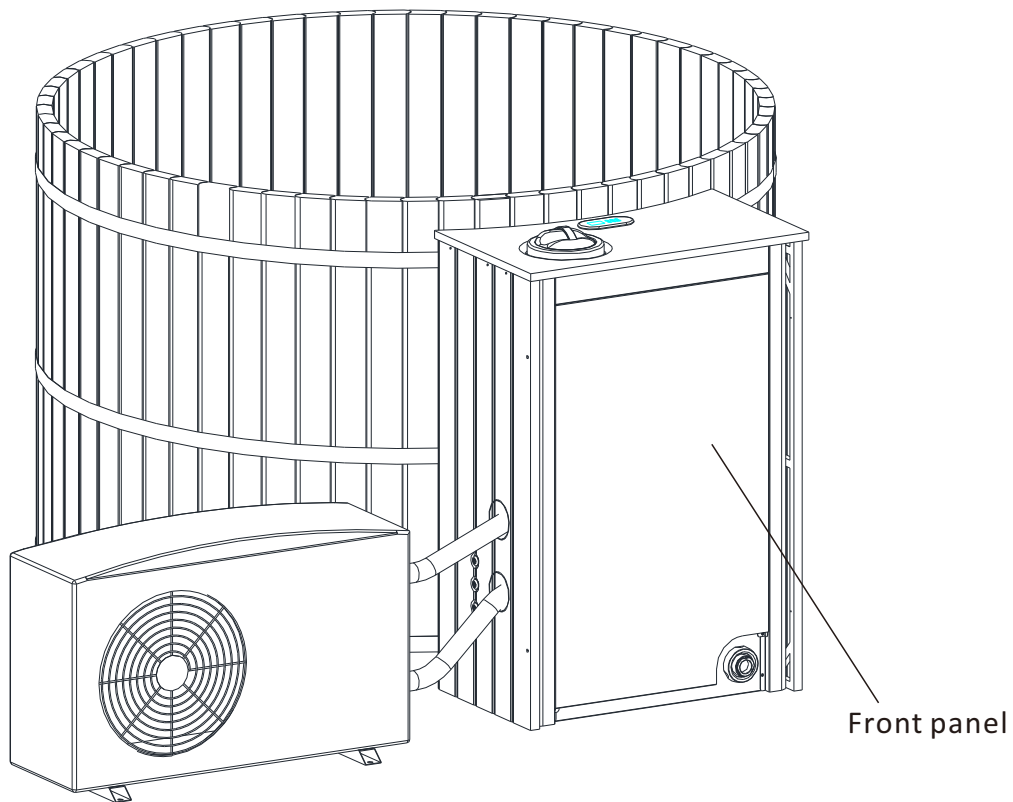

11 Reinstall the front cedar skirt

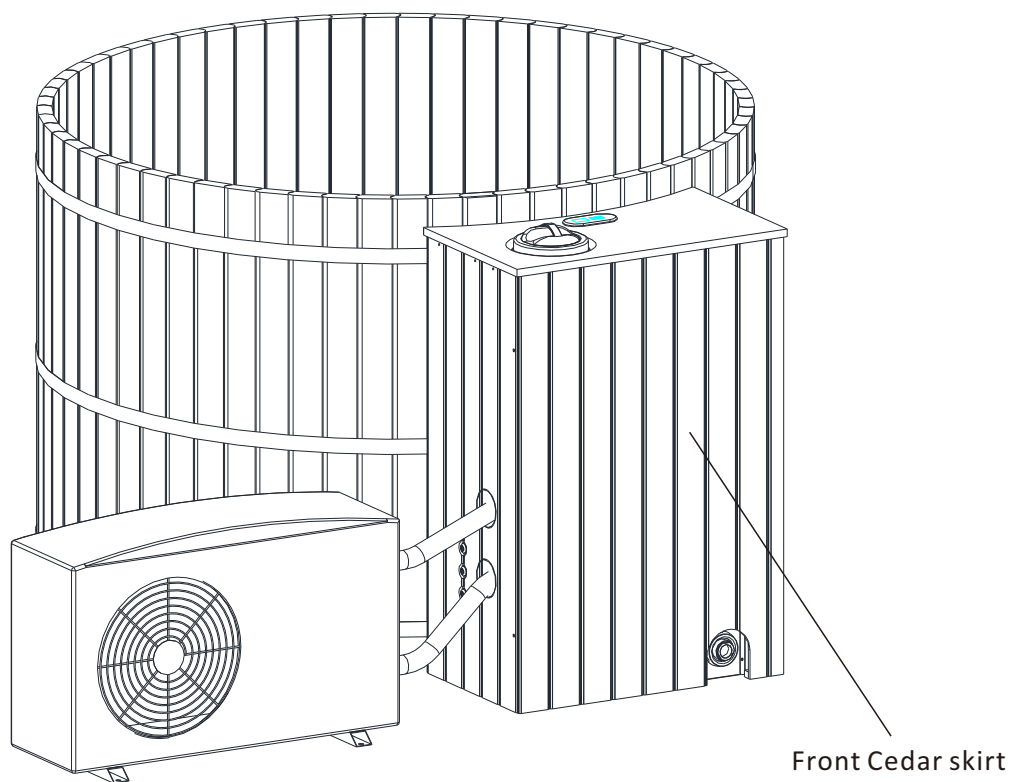

# ◆ Operation guide

## ◇ ELECTRICAL INSTALLATION

- All electrical connections must be performed by a licensed electrician and must conform to all national, state and local electrical codes in effect at the time of installation.
- The appliance should be supplied through a residual current device (RCD) having a rated residual operating current not exceeding 30mA.
- The supply line should be a dedicated power circuit. The installer should consider the sum total load of all devices connected to the SV Mini controller when determining the size of the power circuit and install an appropriately sized circuit breaker to suit. Ensure circuit breaker is rated for motor start up currents. Maximum rated power circuit is 25A.
- Heater load shedding is set by default, so that the heater load sheds and turns off as soon as any device other than Pump 1 is switched on. The installer should consider this when determining the size of the power circuit required. Heater load shedding can be adjusted if desired. Refer to "Heater Load Shedding" section on page 18 of this manual for further information.

## Electrical Specifications

Model	Max Current	Input Voltage	Phases	Hz	Heater Size
Mini 1	25A	230-240V AC	1	50/60	1.5kW / 2.0kW / 3.0kW

## Wiring Diagram (Mini 1)

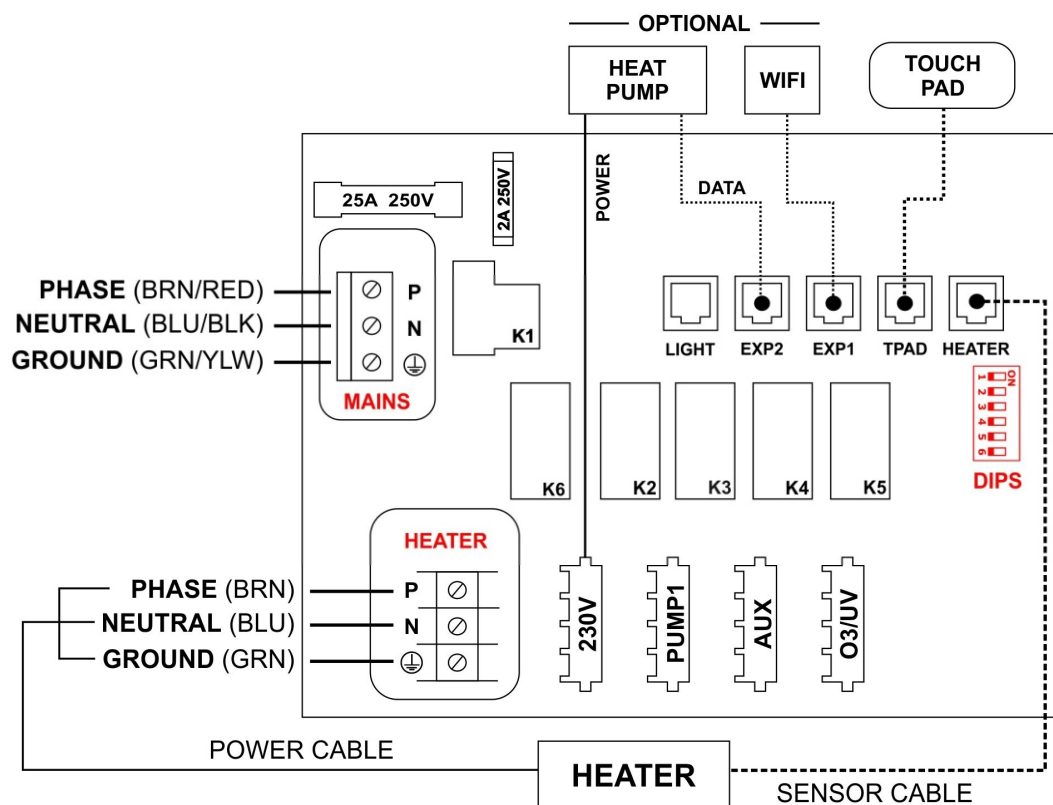

## Output Ratings

Model	Outlet	Max Current	Output Voltage	Hz	Typical Accessory
SV Mini 1	230V	10A	230-240V AC	50/60	Heat Pump / Stereo
	Pump 1	10A	230-240V AC	50/60	Circ / 2-spd or 1-spd Pump
	Aux	10A	230-240V AC	50/60	1-spd Pump / Air Blower
	O3/UV	2A	230-240V AC	50/60	Ozone / UV Sanitiser

## ◇ TOPSIDE PANELS

### SV Mini 1 Layout

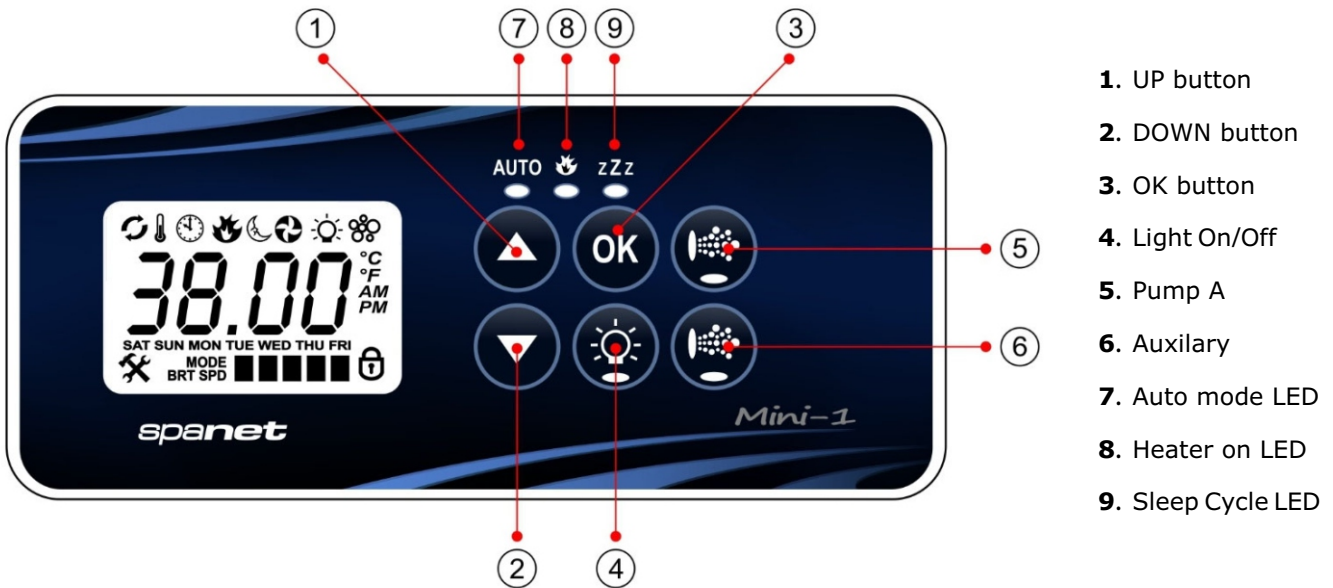

#### DISPLAY MODE ICONS

- Water Temperature
- Set Temperature
- Clock

#### MENU ICONS

- Sleep timer menu icon
- Light menu icon
- Blower menu icon

#### STATUS ICONS

- Keypad locked
- Sanitise cycle operating
- Filtration cycle operating
- Fault condition has occurred

## LED Indicator Lights

The topside panel function buttons (i.e. Pumps, Light, and Blower) feature a green LED light to clearly indicate whether the accessory is ON or OFF. The green LED will light up when the accessory is ON. In addition, the topside panels have three red indicator LEDs to advise the user the current status of the spa:

### AUTO AUTOMATIC MODE

The AUTO LED indicator turns ON when the filtration pump is in automatic mode. In automatic mode the filtration pump will turn on / off as required to satisfy heating and filtration requirements. If the filtration pump is manually turned on or off the AUTO LED indicator turns OFF. The control will automatically return to AUTO mode after a 45 minute idle timeout period if not returned to AUTO mode by the spa user.



### HEATER ON

The Heater LED indicator turns ON when the heater element is active. The heater is automatically controlled, it will turn ON and OFF as required (in conjunction with the filtration pump) to maintain the set water temperature. If the filtration pump is manually turned OFF the heater will NOT operate.

**NOTE:** In some configurations, engaging high speed on a 2 speed pump or operating multiple pumps will cause the heater to load shed and turn OFF (even if heating is required) to keep the system within its rated power supply.



## zZz SLEEP CYCLE ON

The Sleep Cycle LED indicator turns ON when the spa control is within a designated sleep cycle (if set). During a sleep cycle, all automatic system operation will stop so that the spa is silent – i.e. filtration and heating will not occur.

## Display Modes

The SV Mini has three (3) x display modes. The spa user can scroll through the different displays by pressing a short single press of either the UP ▲ or ▼ DOWN button. Each display has a unique icon to indicate the current mode being viewed. As you scroll through each mode a brief title screen will be shown followed by the actual display mode (note change in icon). The available display modes are as follows:



ICON	TITLE	DISPLAY
------	-------	---------



	<b>W.TMP</b>	Water Temperature
	<b>S.TMP</b>	Set Temperature
	<b>TIME</b>	Clock

### NOTES:

1. The default display mode is (W.TMP) water temperature.
2. There is a 10 second inactivity timeout on all non-default displays. No button press for 10 secs display reverts to default.
3. If no icon is displayed the temp shown is from when the filter pump last ran. Once the filter pump next runs for 10 mins the temp will update and W.TMP icon will return.

### OTHER DISPLAY ICONS

	<b>Filtration Cycle</b> The spa is carrying out filtration
	<b>Sanitise Cycle</b> The spa is carrying out a sanitisation cycle

	<b>Keypad Locked</b> The keypad has been locked
	<b>System Error</b> A fault has been detected. The system has halted operation so that corrective action can be taken. Take note of scrolling error code and consult trouble shooting section of this manual.



## SET DATE/TIME BEFORE USING THE SPA

Vital control functions require the date & time to be set correctly. Be sure to accurately set the date and time before operating the spa.

## WATER CHEMISTRY MAINTENANCE

It is your responsibility to regularly check and maintain the chemical water balance of the spa pool to ensure it remains within reasonable pH (acid/alkaline) limits => (7.4 - 7.6 pH). Unbalanced water chemistry greatly accelerates corrosion and may lead to early product or component failure. **Product or component failures caused as a result of poor water chemistry maintenance will NOT be covered by the SpaNET™ Product Warranty.** We recommend you carry out a daily water chemistry test to correctly maintain the pH balance within reasonable limits.



## ◇ SETTING THE DATE/TIME

Be sure to set the date and time before operating the spa. Vital functions such as filtration, sanitisation cycles and sleep timer settings depend on the time and date being set correctly.

- Press a short single press of the DOWN button to change display to Time/Clock setting
- Press the OK button to enter date/time adjustment
- The settings appear in the following order:
  - o Time Format (24 hr / 12 hr)
  - o Year (yyyy)
  - o Month (mm)
  - o Day (dd)
  - o Weekday (mon-sun)
  - o Hours (xx:00)
  - o Minutes (00:xx)
- Press the UP or DOWN buttons to adjust each setting
- Press the OK button to confirm each setting and skip to the next one
- Once the minutes have been selected and confirmed the system will exit the date/time adjustment and the display will return to the default display mode

### NOTES:

1. Leap years are taken into account.
2. The system does not automatically adjust for daylight savings times. User must adjust manually.
3. The date/time clock has a capacitor backup which will hold the date/time even if mains power is turned off. The capacitor backup will last 8-12 hours. If power remains off for longer than this period the date/time may need to be set again.

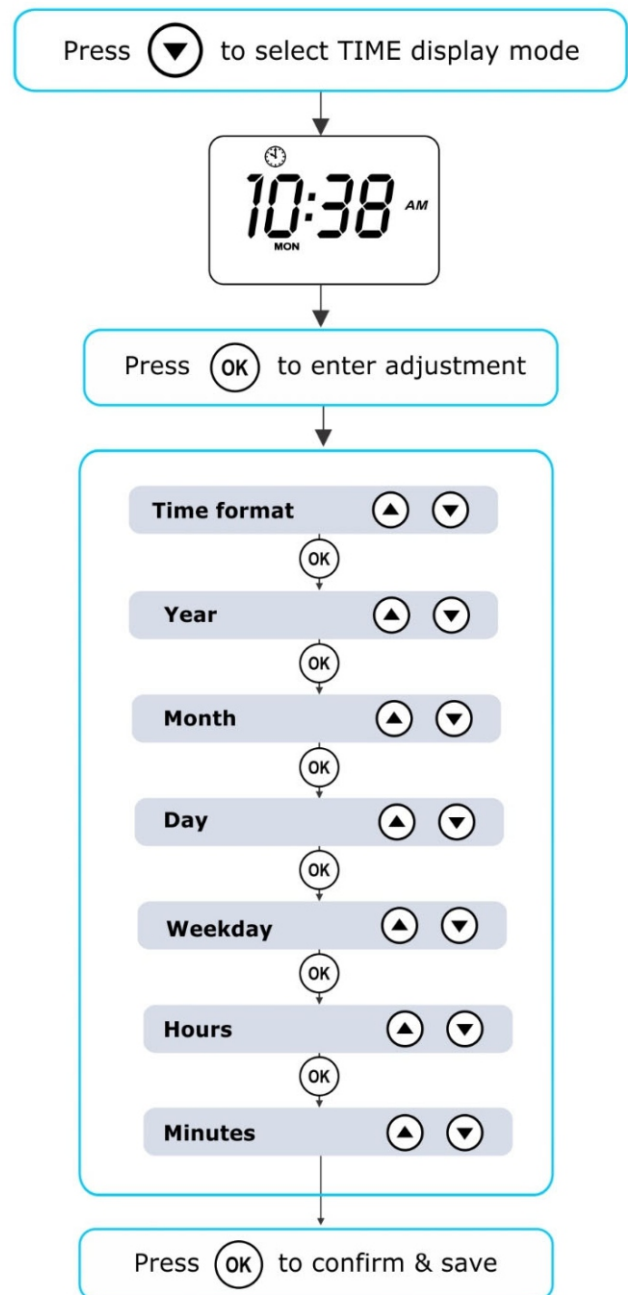

## ◇ AUTOMATIC HEATING / FILTRATION

The SV Mini spa controls have been designed with simplicity in mind. Their intelligent software constantly monitors the spa water, automatically controlling the heater and filtration pump to ensure the desired set water temperature is maintained and required level of daily filtration achieved.

With set-and-forget technology, the spa user simply selects their desired water temperature (10°C - 41 °C. Default = 38 °C) and thereafter the spa control will automatically heat to and maintain that selected water temperature. This is called demand heating - the filtration pump and heater will be activated when required to maintain the set water temperature. The time spent heating the pool and running the filtration pump under normal operation will be taken into account and where required the pump will run for additional periods every three hours to maintain the minimum level of daily filtration as set by the user.

Dependant on the amount of normal spa use, set water temperature, minimum hours of filtration per day, climatic conditions and season being experienced, the spa control will engage the heater and / or filtration pump for differing periods of time, at differing times of day. The advanced software constantly monitors and recalculates after each heating / filtration cycle to ensure the correct daily filtration time is achieved and desired set water temperature is maintained.

Unless adjusted the SV controller will automatically heat to and maintain the default temperature of 38°C. The water temperature set point can be adjusted from 10°C to 41°C in steps of 0.2°C increments.

## Adjusting Set Temperature

- Press and hold the UP or DOWN button to begin set temperature adjustment
- The display will show the (S.TMP) set temperature indicator icon, the main digits flash and temperature will begin adjusting
- Press the UP or DOWN buttons to adjust the set temperature by 0.2 °C increments to your desired temperature
- Press OK to confirm and save setting, or wait for the 10 second idle timeout. The main digits will stop flashing and display returns to default display mode

### NOTES:

1. During a heating cycle the SV Mini may raise the water temperature up to 0.5°C above set temperature point to provide an average water temperature of set point at most times.

2. If an optional heat pump is **NOT fitted** the spa controller has **NO** ability to cool the spa water. Lowering the set temperature point will NOT cause the water to cool.

3. If an optional heat pump **IS fitted** the spa water **CAN** be cooled as well as heated. Lowering the set temperature point will ensure the heat pump engages/disengages a cooling cycle (if required) to maintain the desired set water temperature so long as H.PMP mode is set to AUTO.

4. If the spa control has been in standby mode (idle) for some time and the set temperature point is adjusted, the filtration/circulation pump may run for up to ten (10) minutes to complete a mixing cycle before the heater / heat pump engages to heat or cool (heat pump only) the water. To skip this mixing cycle and begin heating/(cooling) immediately press the PUMP A button multiple times to toggle the filtration pump through ON/OFF/AUTO. Once AUTO is re-engaged the heater will activate immediately.

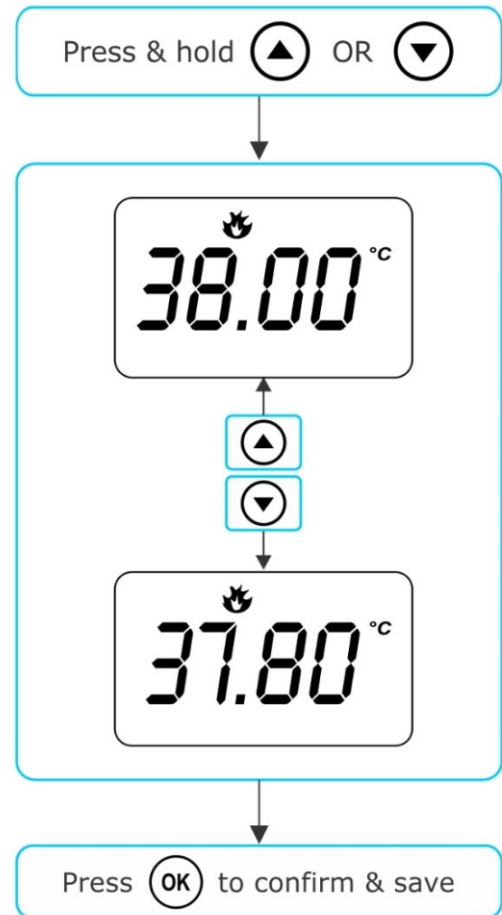

## ◇ PUMP OPERATION

A designated filtration pump (pump 1) will automatically switch on and off as required to perform filtration and heating functions. All pump(s) will also operate for a short period during the daily sanitise cycle. In addition, the following manual pump controls are provided and will override automatic control.

The pump buttons are located on the right-hand side of the topside panels. The functions of the pump buttons change depending on pump configuration, however the Pump-A button is used to control the filtration pump (pump 1). For every press of a pump button the screen will temporarily display the selected pump state: ON, OFF, LOW, HIGH or AUTO and then revert to the default display mode. Possible pump configurations & button sequences are referenced in the tables below:

## SV Mini 1 Pump Buttons

SPA CONFIGURATION	PUMP A BUTTON	AUXILIARY BUTTON
<b>Pump 1 = 2 speed</b> Aux = Not Fitted	<b>2 speed pump:</b> Low / High / Off / Auto	-
<b>Pump 1 = 1 speed</b> Aux = Not Fitted	<b>1 speed pump:</b> On / Off / Auto	-
<b>Pump 1 = 2 speed</b> Aux = 1 speed or Blower	<b>2 speed pump:</b> Low / High / Off / Auto	<b>1 speed pump or Blower:</b> On / Off
<b>Pump 1 = Circ or 1 speed</b> Aux = 1 speed or Blower	<b>Circ pump or 1 speed pump:</b> On / Off / Auto	<b>1 speed pump or Blower:</b> On / Off

### NOTES:

1. If left ON, pumps automatically turn OFF after a 30 minute time-out period from the last button press.
2. If pump 1 is operating and heater is ON and pump is to be switched OFF, the pump will turn off after a 5 second delay to allow the heater to cool down.
3. In some configurations, engaging high speed on a 2 speed pump or operating multiple pumps will cause the heater to load shed and turn OFF (even if heating is required) to keep the system within its available power supply.



## ◇ LIGHT OPERATION

### Multi-colour LED lighting effects

The light button is used to toggle the spa light(s) ON / OFF and to access the light mode menus. The features that can be adjusted are the light colour, light effect mode, light effect transition speed, and light brightness. All light settings are saved and will be restored the next time the light is turned ON, for future ON / OFF use.

## Selecting Light Colour or Effect Mode

Press the LIGHT  button to turn light(s) on/off => light will display last used light mode. If no changes are required there is no need to do anything further. If however you wish to adjust the light settings refer below:

Use the UP  or DOWN  buttons to toggle between the two light modes:

TITLE	MODE	DESCRIPTION
U.CLR	User Colour	Select from 7 possible colours
FADE	Fade Effect	Fade transition through all colours



### User Colour Mode

If user colour mode is selected press OK or wait 10 seconds for the display to show the current selected colour number. There are 7 colours to choose from (CL:00 -CL:07). Use the UP or DOWN buttons to adjust the colour. Press OK to confirm and skip to the light brightness adjustment or wait for the 10 second inactivity time out.

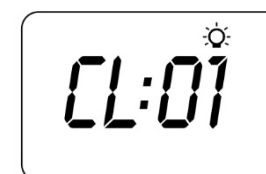

## Fade Effect Mode

If fade effect mode is selected press OK or wait 10 seconds for the display to show the light speed (L.SPD) adjustment screen where the speed of the fade transition between colours can be adjusted. Use the UP or DOWN buttons to increase or decrease the transition speed to your desired level. Press OK to confirm and skip to the light brightness adjustment or wait for the 10 second inactivity time out.



## Light Brightness

Once light mode and colour or light speed has been selected the controller offers a light brightness adjustment. Use the UP or DOWN buttons to increase/decrease the light brightness to your desired level. Press OK to confirm or wait for the 10 second inactivity timeout.



### NOTES:

1. The light mode / user colour / light speed / light brightness adjustment screens are only displayed for 10 seconds each when the light(s) are first turned ON. If no adjustment is made the light(s) will run as per the last used settings, and the screen will time-out and revert to the default display mode. If you wish to adjust the light(s) settings once the light(s) have been running for a period of time, the light(s) must be turned OFF and back ON again to restore the light mode adjustment screens.

2. If left ON, the light(s) will automatically turn OFF after a 45 minute time out period from the last button press.

## ◇ KEYLOCK FUNCTION

### How to set full or partial keylock

The keypad buttons can be locked to prevent accidental key presses or to limit access to certain controller functions. This feature is helpful where children are present or spa is used by many people.

There are two types of keylock:

- |              |  |
|--------------|--|
| Full Lock    | All buttons are disabled   |
| Partial Lock | Allows use of pumps, blower and light but locks out settings and temperature adjustments |

### Full Lock

- Press and hold **UP + DOWN + PUMP A** until LOCK appears on the display
- Once locked if any button is pressed the key stroke will be ignored and display will show LOCK
- To unlock press and hold **UP + DOWN + PUMP A**



### Partial Lock

- Press and hold **UP + DOWN + PUMP B** until LOCK appears on the display
- Once locked only pumps, blower and light can be used. Other key strokes will be ignored and display will show LOCK
- To unlock press and hold **UP + DOWN + PUMP B**



## ◇ AUTO DAILY SANITISE

The controller will automatically run a 10 minute sanitise cycle every day at 9:00am. This sanitisation cycle runs the filtration pump and ozone/UV (if fitted) to filter the pool water to restore and refresh water quality. If pump 1 is a 2 speed pump the pump will run in high speed for the duration of the cycle. In addition at the start and end of the cycle the controller will sequentially run any additional accessories (auxiliary, pump2, pump3 or blower if fitted) for one minute each to purge the plumbing and clear any unfiltered water trapped in those accessory lines.

### NOTES:

1. If the controller is in a programmed sleep period at 9:00am it will wait until the sleep period ends before the daily sanitise cycle runs.
2. If the spa is in use prior to the 9:00am sanitise cycle start time the cycle is cancelled for the day. Spa in use = button has been pressed and spa has not had the 45 minute inactivity time out expire since the last button press.

## ◇ SETUP MENU

The SV Mini controllers feature a setup menu which allows customisation of adjustable software settings. These settings do not need to be modified often and in most cases the default settings are all that is required, however if the spa owner wishes to customise any settings it is completed through the setup menu.

- To access the setup menu press and hold the UP + DOWN buttons simultaneously until display shows FILT
- Use the UP or DOWN buttons to navigate through setup menu items
- Press the OK button to enter setting adjustment
- Press the UP or DOWN buttons to adjust setting
- Press the OK button to confirm and save the setting adjustment

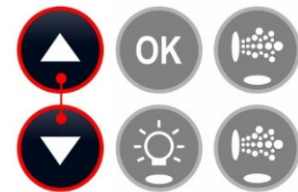

Refer table on the following page for details on setup menu items:

### Setup Menu List

ITEM	SETTING	NOTES
<b>FILT</b>	Hours of filtration per day	Adjustable from 1 to 24 hours
<b>SNZE</b>	Sleep Timer Menu	
1.SNZ	Sleep timer 1	[1.DAY] Days of week, [1.BGN] Begin Time, [1.END] End Time
<b>D.DIS</b>	Default display mode	Water Temp (W.TMP) / Set Temp (S.TMP) / Clock (TIME)
<b>WIFI</b>	WiFi Setup Menu	
HOT	Hot spot mode	Activates hot spot mode for WiFi setup process
INFR	Infrastructure mode	Force a disconnect/reconnect to WiFi server to refresh connection
RSET	Reset WiFi module	Deletes all settings and prepares WiFi module for setup process
<b>H.PMP*</b>	Heat pump mode	Auto (heat & cool) / Heat only / Cool only / Off (HP disabled)
<b>H.ELE*</b>	HP + element boost	Off = heat pump only, electric heater disabled (default setting) On = heat pump + electric heater combined for heating

\* H.PMP and H.ELE setup menu items will only be visible if a SV Series heat pump is installed and connected to the SV Mini control.

**Notes:**

- 1. The setup menu settings are stored in non-volatile memory (EEPROM) and are remembered when the mains power is turned OFF. No need to reprogram settings when power is restored.
- 2. A ten (10) second idle menu time out period exists. If a button press is not detected for 10 seconds the menu will time out and the screen will return to the default display mode.

### FILT-Filtration (total hours per day)

Automatic filtration is provided to ensure that the pool water is filtered for at least a minimum number of hours each day. Total daily runtime can be adjusted from 1-24 hours (default = 2 hours). Total filtration runtime is broken into smaller blocks which occur every three hours. All time spent running the pump under normal operation (manual use, heating, sanitise cycle) will be taken into account and where required the pump will run for additional periods throughout the day to maintain the minimum level of daily filtration as specified by the user.

### SNZE -Sleep Timer

The sleep timer is a very handy feature that enables the user to stop all spa activity and silence the spa during certain times of day or night. While the controller is sleeping NO automatic heating or filtration maintenance will occur, however the spa can still be operated by manual use without the need to adjust sleep time settings. The sleep timer setup consists of defining days of operation and begin time and end time of sleep period. Use the UP or DOWN button to adjust each setting within the sleep setup and press OK to confirm and skip to the next setting. Sleep timer settings are referenced in the table below:

TITLE	SETTING	OPTIONS
1.DAY	Selected days of operation	Sat-Fri (7 days), Sat-Sun (weekend), Mon-Fri (weekdays), OFF
1.BGN	Time sleep period begins	Adjustable to any time 0:00 to 23:59 (Default = 22:00 PM)
1.END	Time sleep period ends	Adjustable to any time 0:00 to 23:59 (Default = 07:00 AM)

**Notes:**

- 1. SV Mini is preset with a default sleep timer – 7 days a week, begin 22:00 (10PM), end 07:00 (7AM)
- 2. Set 1.DAY=OFF to disable sleep timer
- 3. If spa in use at begin time of sleep period, spa will not sleep until 45 min inactivity timeout has elapsed

### D.DIS -Default Display

The user can adjust the default display mode to show their preferred selection of either: **W.TMP** (water temperature), **S.TMP** (set temperature) or **TIME** (current time and day).

### WIFI -WiFi Setup

This menu is only of use if the optional SpaNET SmartLINK or SmartSTREAM WiFi module has been installed and connected to the SV Mini. This menu has three commands that can be executed. Use the UP or DOWN buttons to select desired command and press the OK button to execute – display will show WAIT whilst the WiFi module carries out the command.

- HOT** Puts WiFi module in hot spot mode for initial app setup. Note: Once initial app setup has been completed if the HOT command is executed again all WiFi settings will be lost and the app setup process must be run again.
- INFR** Forces WiFi module to disconnect/reconnect from the SpaNET app server to refresh connection if spa is not automatically coming online once the app setup process has been completed.
- RSET** Deletes programmed settings from WiFi module and returns the module to its factory default state. Note: If this command is executed settings are lost and the app setup process must be run again.

## H.PMP -Heat Pump Mode

This setting is only visible if a SV Series heat pump is connected and defines heat pump operating mode. The available operating modes are as follows:

- AUTO** Heat pump will heat and cool
- HEAT** Heat pump will only heat (Default)
- COOL** Heat pump will only cool
- OFF** Heat pump disabled

## H.ELE -Heat Pump + SV Element Boost

This setting is only visible if a SV Series heat pump is connected and defines how the SV Mini electric heating element operates with a heat pump. By default, this setting is set to OFF which disables the electric heater using only the heat pump for heating. Set to ON to allow the electric element to run in conjunction with the heat pump to boost heating speed if the water temperature is 2°C or more below set temperature point or the heat pump has been operating for more than 1 hour and set point has not been achieved. The H.ELE setting choices are:

- OFF SV element disabled (heat pump only)
- ON SV element + Heat Pump for heating

## ◇ OEM CONFIGURATION MENU

SV Mini controllers feature a hidden OEM configuration menu which allows customisation of certain important spa control settings.

- To access the OEM config menu on a SV Mini 1 press and hold the hidden buttons (shown by the red dotted circles aside) simultaneously until display shows L.SHD. For SV Mini 2 press and hold the PUMP C + BLOWER buttons simultaneously (refer aside)
- Use the UP or DOWN buttons to navigate through the configuration menu items
- Press the OK button to enter setting adjustment
- Press the UP or DOWN buttons to adjust setting
- Press the OK button to confirm and save the setting adjustment



Refer table on the following page for details on configuration menu items:

### OEM Configuration Menu List

ITEM	SETTING	NOTES
L.SHD	Heater Load Shedding	Load Shed count adjustable from 1 to 5 loads (default 1 load)
A.HYS	Adaptive Hysteresis Limit	0 to 20 °C, 0.2 °C increments (0=disabled)
CAL	Calibrate Menu	Calibrate voltage, heat pump ambient & condenser temp sensors
EPRM	Reset EEPROM to default	All software values re set to factory defaults

## L.SHD -Heater Load Shedding

This setting determines the load shed behaviour of the heating element or heat pump (if fitted). Load shedding is governed by the load shed count (1 to 7). Load shed count = number of loads required to be turned ON for the heater to load shed and turn OFF. The filtration pump is not counted as a load, however all other pumps and the blower are.

**Note:** For 2 speed pumps, low speed is considered as the filtration pump and therefore is NOT a load, however high speed IS considered a load for load shed count purposes.

**Example:**

Load Shed Count = 2

When any two loads in addition to the filtration pump are turned ON the heater load sheds and turns OFF.

The L.SHD setting ranges from 1 to 5.

1 = maximum load shed (default)

5 = load shed disabled

 **IMPORTANT NOTE**

**BE VERY CAREFUL BEFORE ADJUSTING THE L.SHD SETTING** - If the heater load shedding (L.SHD) setting is adjusted it will alter the total current draw of the controller and may EXCEED the maximum rated current of the control system or available power supply. **Only qualified service persons or licensed electricians should adjust this setting to ensure the spa remains within the maximum rated current of the spa control or power supply when operated.**

## A.HYS - Adaptive Hysteresis (Dynamic Thermal Tuning)

The SV Mini controllers feature adaptive hysteresis for heat control to reduce demand heating cycling. Adaptive hysteresis control tunes the temperature sensing to that particular spa pool and environment. The control starts with an initial hysteresis value of 2°C however this value will automatically increase or decrease as the dynamic thermal tuning learns and adjusts to the thermal properties of the spa. The A.HYS setting allows the installer to set the maximum range that the hysteresis value can be adjusted out to.

The A.HYS setting ranges from 0 to 20°C

A value of 0 disables adaptive hysteresis

Default = 20°C

## CAL - Calibration Menu

Every SV Mini is calibrated at factory for mains voltage readings. However, should the SV controller reading not agree with a true RMS multi meter reading it can be adjusted. In addition, if a heat pump is fitted the calibration of the heat pump ambient and condenser temperature sensor readings can be adjusted which can be required if the standard length data cable on the heat pump is replaced with a longer cable. Refer to heat pump user manual for further instructions on how to accurately perform that calibration. Refer to the table on the following page for details on the calibration sub menu:

### Calibration Menu List

TITLE	SETTING	OPTIONS
V.ADJ	Mains Voltage Adjustment	Use the UP or DOWN buttons to adjust reading
H.AMB	Heat Pump Ambient Thermistor	Use the UP or DOWN buttons to adjust reading
H.CON	Heat Pump Condenser Thermistor	Use the UP or DOWN buttons to adjust reading

## EPRM - Factory data reset

Execute this command to perform a master software reset to return all settings to factory defaults.

- When EPRM is displayed on screen press the OK button to execute the software reset
- The display will very briefly flash ESET as the reset process takes place
- It is best practise to then reset the mains power (i.e. turn off/on) to reboot the control if an EPRM factory reset has been performed

**Note:**

All software values are reset to factory default EXCEPT the L.SHD (load shed) setting as the L.SHD setting will have been customised to suit the particular spa pool and its available power supply by the spa manufacturer or installing electrician.



## ◇ DIAGNOSTIC MENU

The SV Mini controllers feature a hidden diagnostics menu which allows the installer / spa user to view onboard diagnostics and historical details about the spa controller.

- To access the diagnostic menu on a SV Mini 1 press and hold the LIGHT + hidden buttons (shown by the red dotted circles aside) simultaneously until display shows WARN. For SV Mini 2 press and hold the LIGHT + PUMP C + BLOWER buttons simultaneously (refer aside)
- Use the UP or DOWN buttons to navigate through the diagnostic menu items
- Press the OK button to display the diagnostic information on the selected item



### Diagnostic Menu List

ITEM	SETTING	NOTES
<b>WARN</b>	Warnings data scroll	Maximum (Vmax) and minimum (Vmin) voltages ever recorded and max. and min. recorded in last 24 hrs (Vmax24/Vmin24)
<b>S.DAT</b>	Start date scroll	Start Date recorded after 168 hrs (7 days) continual use (dd-mm-yy)
<b>S.VER</b>	Software version scroll	Controller firmware version installed [ Vx (yy-mm-dd) ]
<b>TYPE</b>	Controller type scroll	Displays controller model
<b>PUMP</b>	Pump selection scroll	Lists pump configuration based on dip switch settings
<b>LIMS</b>	Limits scroll	Load shed count, load limit count, pool & heater hysteresis values
<b>H.TMP</b>	Heater temperature	Current heater temperature reading
<b>C.TMP</b>	Case temperature	Current case temperature of SV Mini enclosure
<b>VOLT</b>	Voltage	Current voltage reading
<b>H.AMB</b>	Heat pump ambient	Heat pump ambient thermistor temperature
<b>H.CON</b>	Heat pump condenser	Heat pump condenser thermistor temperature
<b>H.COM</b>	Heat pump compressor	Heat pump compressor thermistor temperature

## ◇ HEATING CONTROL & PROTECTION

### Fast Heat Cycle / Freeze and Overheat Protection

#### Fast Heat Cycle

After initial mains power on the SV Mini will perform a fast heat up cycle that enables continuous demand heating regardless of programmed/default sleep timer. Once the set temperature has been reached the fast heat up cycle is cancelled and normal operation resumes and sleep timer is obeyed. The purpose of a fast heat up cycle is to help the spa reach set temperature as soon as possible after it has been powered up. For new spas or spas refilled with cold water it is desirable not to have sleep time delaying the time it takes for the spa to reach set temperature point.

#### NOTES:

1. A fast heat up cycle is cancelled by manually forcing the filtration pump to OFF via the keypad
2. For new spas or when a spa has just been refilled it is common for spa users to test the operation of each pump when the power is first turned on. This process will cancel the fast heat up cycle. After completing testing of the spa functions remember to reset mains power if you wish to reactivate fast heat up cycle.

## Freeze Protection

Freeze protection will be activated whenever the water temperature drops below 4°C. It runs back to back 10 minute sanitise cycles and displays “WARM” on the LCD. It also runs each spa accessory (i.e. jet pumps and air blower) in sequence to run water through the pipe work whilst running the filtration pump and heater. During the “WARM” cycle the heater and heat pump (if fitted) will operate however heater load shedding may occur when accessory pumps are running depending on control and load shed settings.

At the end of each 10 minute “WARM” cycle the water temperature is checked. If it is above 4°C freeze protection stops and the controller returns to its prior state. If the temperature is not above 4°C another cycle will run.

**Note:** Freeze protection overrides the sleep timer– if the water temperature drops below 4°C and the controller is in a sleep period it will wake up. So even if high amounts of sleep time and a low set temperature point have been programmed, the SV Mini will always maintain the water temperature at least above 4°C.

## Defrost Cycle (heat pump models only)

During periods of low ambient temperatures defrost cycles may be required to prevent the heat pump’s condenser from freezing. Ambient and condenser temperatures are constantly monitored and defrost cycles will be automatically activated if certain conditions are met. Defrost cycles run for a minimum of 3 minutes to a maximum of 10 minutes.

## Overheat Protection

All SV controllers feature three forms of overheat protection:

1. If sensed water temperature within the heater unit exceeds safe working limits the heating element will be disabled and the controller will shut down and latch fault code (ER4 - Thermal Trip). Normal operation will not resume until heater element has cooled and mains power is reset
2. If sensed water temperature exceeds 42 °C filtration is stopped until the temperature falls below 42°C to prevent heat rise from filtration pump operation
3. If sensed water temperature exceeds 45 °C the controller will shut down and latch fault code (Er5 - Pool too hot). Normal operation will not resume until mains power is reset

## ◇ ERROR CODES / TROUBLESHOOTING

SV spa controllers feature self-diagnostics and scrolling error messages to quickly troubleshoot possible problems. Should the spa control encounter a problem the error code / message will scroll across the topside panel screen until the problem is resolved. If an error condition is experienced all spa functions are shut down and the spa should not be used until the error condition has been resolved. A list of error codes with descriptions of problems and possible solutions is detailed below for your reference.

### **IMPORTANT NOTE**

**For most error codes mains power to the spa control must be turned OFF and then back ON before the error condition will be cleared.** Before attempting any troubleshooting always ensure mains power is isolated and turned OFF.

### **Heartbeat LED**

All SV Mini spa packs feature a red flashing heartbeat LED light. The heartbeat LED is located on the main printed circuit board of the spa pack itself (spa pack enclosure cover needs to be removed).

The heartbeat LED flashes to indicate the current health/status of the spa pack. When the spa pack is functioning correctly with no errors to report the heartbeat LED emits a single flash in a constant pulse much like a heartbeat (ON, OFF, ON, OFF). If the spa pack encounters a fault the heartbeat LED will begin flashing in sequence with the error code number being experienced (ie. ER2 = ON,ON; OFF ON,ON; OFF).

If the keypad display is ever blank a spa user can still determine the health / status of the SV Mini controller by removing a panel from the spa skirt and checking the heartbeat LED on the front of the spa pack itself.

### **ER-2 HEATER PLUG**

- Problem:** No heater sensor communication
- Cause:** Heater sensor communication problem. Sensor cable is not correctly connected to spa control or is damaged
- Solutions:** Turn mains power OFF, remove spa cabinet panel and SV Mini enclosure cover  
Check heater sensor cable is firmly plugged into spa control socket labelled HEATER  
Unplug and re-plug heater sensor cable to re-establish connection to spa control  
Check for damage to sensor lead, replace covers and test spa again  
Contact spa reseller if problem is not resolved

### **ER-3 WATER PRIME**

- Problem:** Water prime failed – air detected in heater tube
- Cause:** Airlock in pipe work, low water level, dirty filter cartridges
- Solutions:** Press Pump A button to retry water prime  
Check spa water level (refill if necessary)  
Remove filter cartridges and press Pump A button to retry prime  
Bleed airlock from pipe work by slightly loosening couplings on front of filtration pump  
Remove filter cartridges and flush water down pipe work with a hose

### **ER-4 THERMAL TRIP**

- Problem:** Heater thermal trip activated. Heater has been active and has had insufficient water flow over the element. Low or no water flow has caused the heater temperature to exceed its maximum limits and the spa control has shut down operation to prevent any damage to the heater unit
- Cause:** Low water level, airlock in pipe work, closed shut-off valves, dirty filter cartridges, filtration pump failed or operation intermittent
- Solutions:** Turn mains power OFF and wait 20-30 minutes for element to cool and thermal cut-out device to reset. Then turn power back ON  
Check spa water level (refill if necessary)  
Remove filters and clean as per manufacturer's recommendations or replace cartridges if required  
Check under spa cabinet to ensure all shut-off valves are in the OPEN position  
Bleed airlock from pipe work by slightly loosening couplings on front of filtration pump or by removing filters and flushing water down pipe work with a hose.  
Contact your spa reseller if problem persists

### **ER-5 POOL TOO HOT**

- Problem:** Pool over temperature. Temperature sensor reading  $\geq 45^{\circ}\text{C}$
- Cause:** High ambient temperatures (especially in summer months) have caused water temperature to rise above set temp point, Excessive filtration time, Jet pumps have been operating for extended periods with the spa cover still on
- Solutions:** Turn mains power OFF, remove spa cover, allow spa to cool then turn power back ON  
Check daily filtration time (refer filtration section) and reduce daily filtration time if required  
Check spa cover is not resting on topside panel buttons causing jet pumps to start when cover is on. Use keylock function to lock keypad buttons when spa not in use.  
Contact your spa reseller if problem persists

## **ER-6 12V OVERLOAD**

- Problem: 12V (port) current draw over 1A limit
- Cause: Total 12V current drawn by keypad(s), light(s), expansion ports and in pool temp sensor is excessive, 12V power supply is overloaded, too many LED light bulbs installed, faulty LED light
- Solutions: Turn mains power OFF and restart spa to see if problem reoccurs  
Perform EPRM software reset to factory defaults  
Reduce number of LED lights connected to spa control  
Systematically unplug lights, keypads and expansion port loads from spa pack (one by one) to identify the faulty 12v device  
Contact your spa reseller if problem persists

## **ER-8 CTRL FAULT HVS**

- Problem: Heater relay is on when it should be off
- Cause: Power surge, periods of low or high voltage, water on spa pack terminal block, relay fault
- Solutions: Turn mains power OFF and back ON again to see if spa control recovers from ER8 fault  
Inspect under spa cabinet for evidence of water leaking onto spa control. If water present, turn mains power OFF and isolate, then resolve leak, dry up excess water, and allow spa control to dry out before restoring power.  
Contact your spa reseller if problem persists

### △ Safety level

There are two water lines on the spillway.  
The water level in the hot tub has to exceed the first water line before you operate system.

**Note: Do not fill above the second line.**

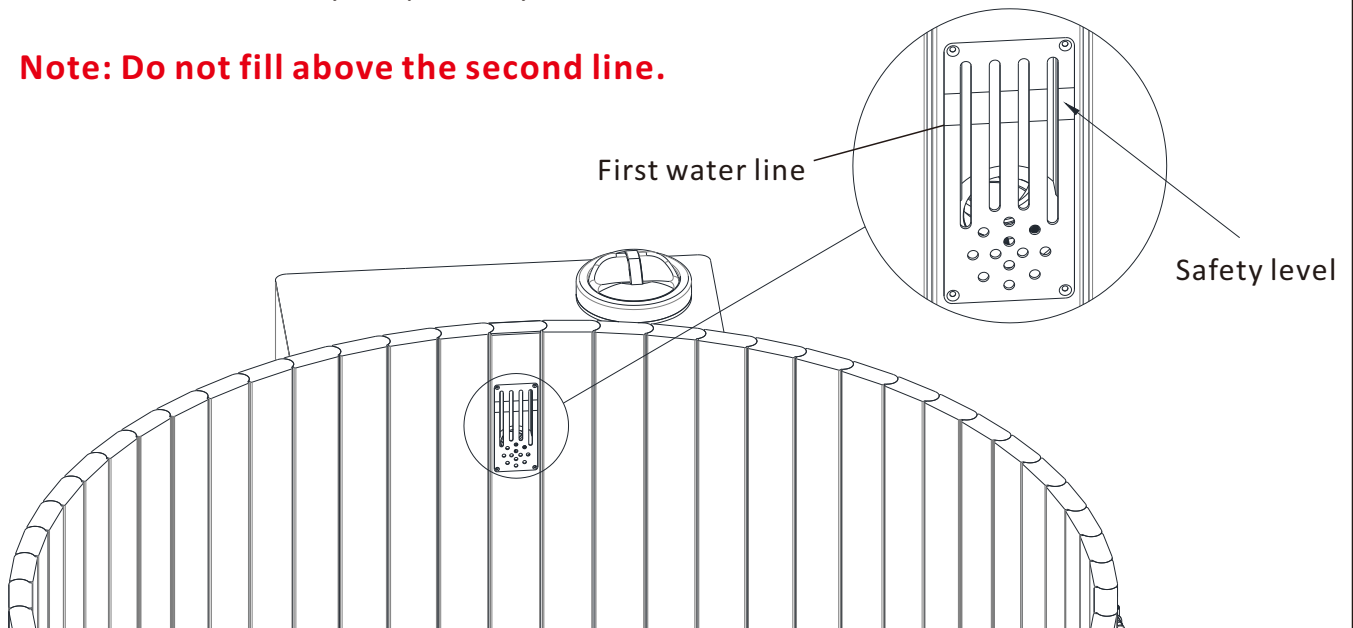

### △ System exhaust

When water level in the hot tub is insufficient, the system will absorb air from the spillway net. At this time, it needs to put water in the appropriate position to exhaust extra air. There is a release valve on the filter. Slowly loosen the valve till you can feel air going out. When all the air is exhausted, it will spray water outside. Finally you just need to tighten the release valve. Attention: before opening the release valve, don't take out the entire release valve as long as there is air going out.

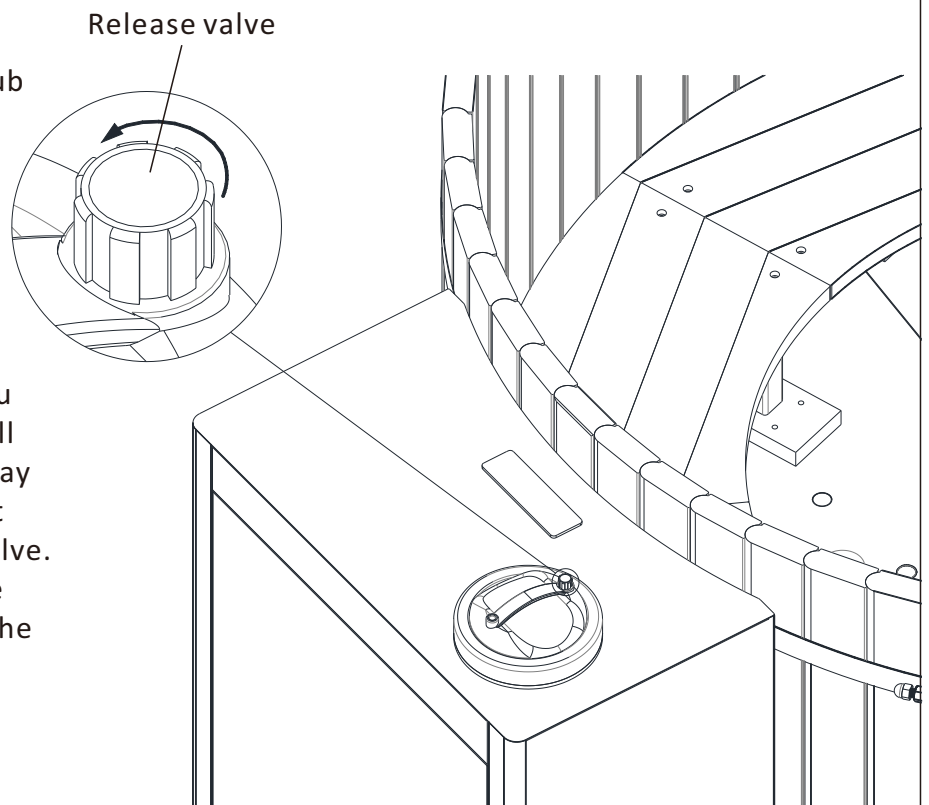

**Note: Please remove the plastic film of filter core before using your hot tub.**

△ Drain valve

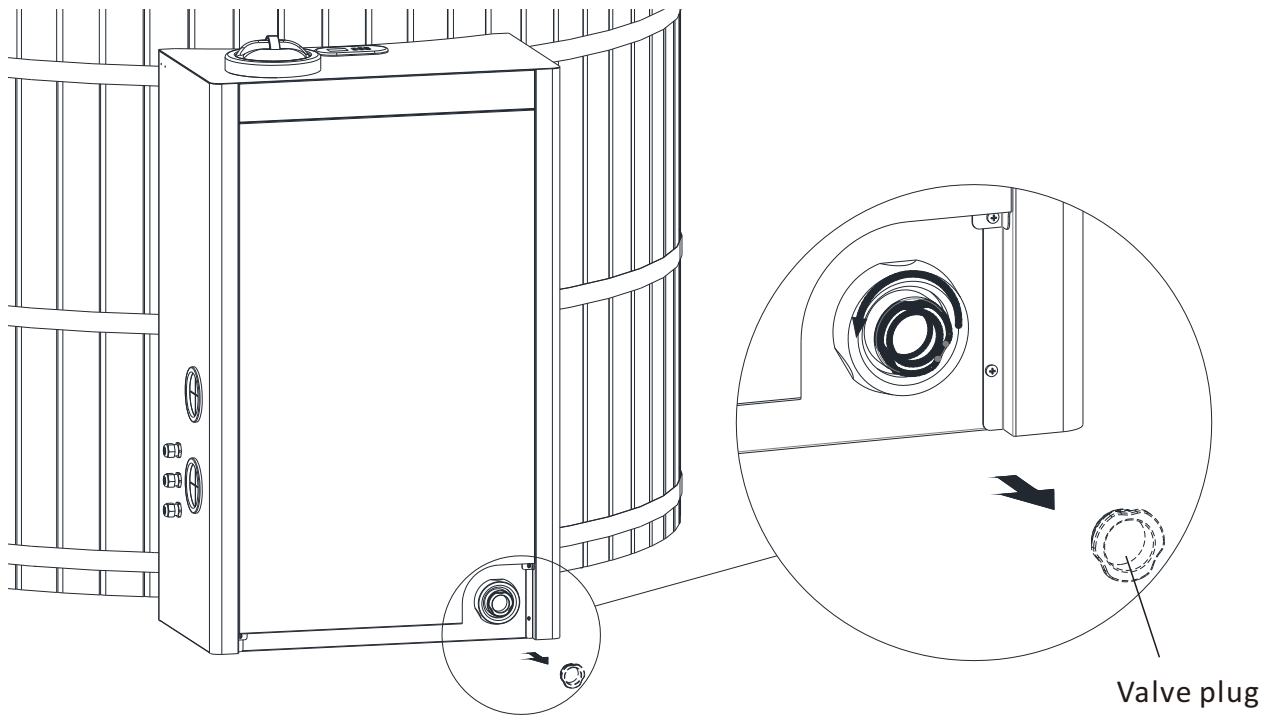

To drain water, first take out the valve plug, and then loosen the valve to drain.

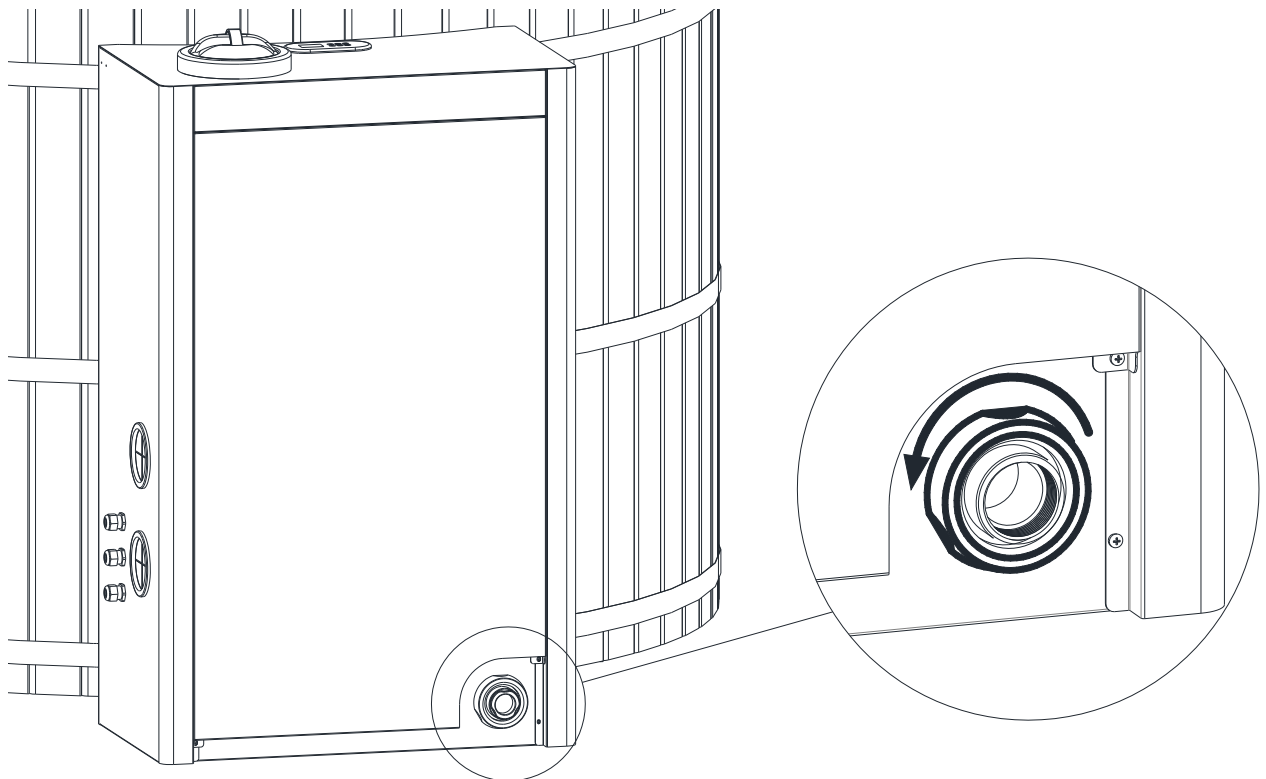

## ◆ Cleaning and maintenance

To protect and lengthen the lifespan of your new

Cedar Hot Tub, please follow instructions below for cleaning and maintenance.

1. When filling the Hot Tub for the first time, please leave water in for several days, allowing the wood to swell, and ensure you are frequently topping it up to enable saturation of wood as it will leak during this time.
2. Slight leakage is a completely normal while the Hot Tub is sealing. If it still leaks after being submerged in water for fourteen days, the leak may be due to assembly and should be structurally inspected. If there are any quality problems, please contact us so we can assist you as soon as possible. If there are any problems during the process of installation, feel free to call us so we can help.
3. Any timber surface exposed to dirt needs to be wiped down promptly to remove dirt and prevent stains. For surface dirt, wipe it first with clean water and cotton cloth. If it is difficult to remove, scrub with banister brush and neutral cleaning agents. Never use acid cleaning agents and hard brushes as this will cause irreversible damage to wood.
4. If the Hot Tub is leaking due to damage to the stave or base, wipe out water around leakage (both inside and outside if possible). Seal with Silicon where the leakage is occurring both inside and outside if possible. Leave to set for 48hours and then refill and reassess.
5. Over time, the steel bands around the Hot Tub will become loose due to aging and shrinkage of wood and may need to be tightened occasionally.
6. Our Hot Tubs are painted with natural wax oil which helps maintain the wood and keep its colour. The oil will not add any chemicals and should be reapplied every 6 months. We recommend cutek.

### △ Cleaning and replacement of paper filter element

The filtration system filters impurities in the water with the paper filter element. It needs cleaning every 5-10 days and replacing every 2-3 months to ensure the filtration effectiveness;

Operation:

Step 1. Lower the water level in the hot tub to the position of the control panel of the control box.

Step 2. Turn locking ring counter clockwise.

Step 3. Open the release valve on the filter cover, and pull out that cover.

Step 4. Now take out the paper element for cleaning or replacement.

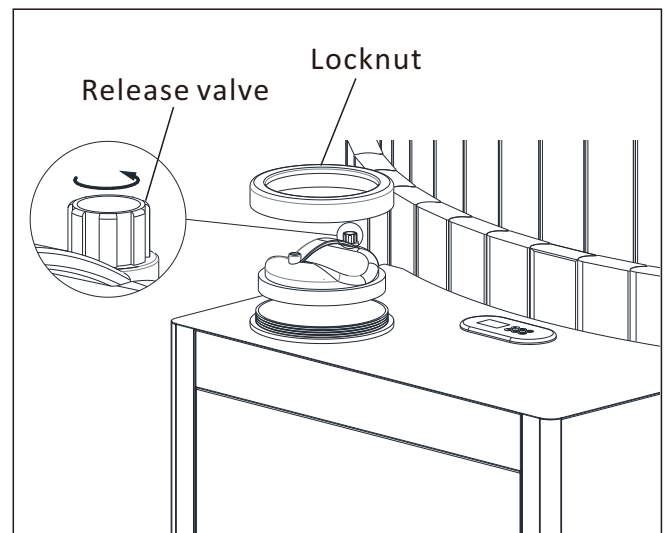

## ◆ Use instructions

1. After the product is installed and assembled, the Hot Tub will leak at first. Your Hot Tub will usually drip for 1-2 weeks before the Cedar swells and seals. You can use it during this time as it helps with sealing the Tub. At the time of the first fill you may even get the occasional trickle, using saw dust supplied can help seal it quicker by pushing a little into the groove on the inside where the water is exiting.
  - a. It is important to fill the tub to the level between the etched lines on the skim grate, but never fill the tub above the top of the grate.  
The next few items relate to the wood fired heater.
2. Prepare paper and dry kindling wood on the grate then light the fire, slowly building it up with small split pieces of firewood. Keep the fire box lid with the air intake open and check fire every 15 minutes or so. Never over fill the fire box, it should only ever be half full.
3. Regularly check the water temperature and close the air vent when you reach your desired temperature. After a few attempts at heating up the water, you will get to know the best method and time for your hot tub to be at your desired temperature.
4. If the fire is managed correctly and built up steadily, then a minimal amount of smoke will be produced. Smoke occurs when there is insufficient heat to burn off all the gases.
5. Before use, stir water in the hot tub with wooden paddle and measure water temperature. Stir up water in hot tub base to make water up and down at the same temperature. You can start to use it when water temperature at each position is the same.
6. If water temperature is too high, please add some cold water into the tub till the water temperature is suitable for bathing.

## ◆ Precautions

1. When using the wood fire stove, water level in the tub must be over the top of outlet.
2. Before using the hot tub, you have to stand outside the hot tub and stir water evenly with wooden paddle, and measure whether water temperature is appropriate.
3. Water temperature inside the hot tub should not exceed 41°C, suitably 38-40 °C recommended for a healthy adult. A lower water temperature is more suitable to children after using the hot tub for more than 10 minutes.
4. When you start to use it, please put out the fire inside the stove. Do not let water temperature continue to rise and leave enough charcoal fire to keep it warm.
5. Heat-insensitive patients or juveniles can only use this product supervised by the normal or adults.
6. It is not recommended to use it after a meal within 30 minutes, no more than 30 minutes every time. To prevent from drowning, Don't drink alcohol, or use drugs while using this product.
7. The following persons are required to use this product only after guidance from doctors:
  - a. Those with skin rupture, abscess, severe wounds
  - b. Those diagnosed with vascular diseases and heart function disorders (hypertension, diabetes, varicose veins, etc.);
  - c. Those with pacemakers;
  - d. Women during menstruation or pregnancy
8. The insulation cover has a built-in password lock which is "00".
9. When using the wood fired stove, please do not directly touch it in case of burns.