

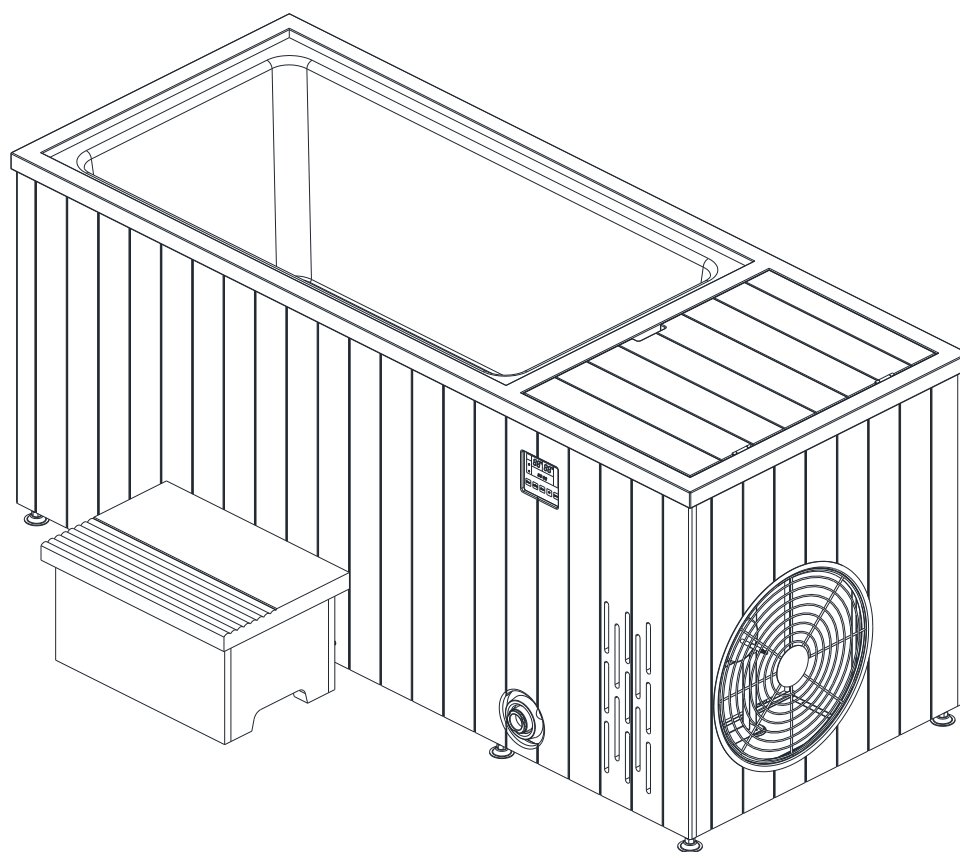

# Cold & Heat Plunge

Owner's Instruction Manual



- Please read this manual carefully before using.
- Please keep this manual for your convenience of future reference.

Please read this manual carefully before using, to take full advantage of its good quality. Please keep this manual available for future reference.

### Contents

1.To users .....	(2)
2.Product Instruction .....	(2)
3.Outline dimensions .....	(4)
4.Pipeline Connection .....	(5)
5.Intelligent Application Instruction .....	(6)
6.Maintenance .....	(14)
7.Unit Protection and Troubleshooting .....	(14)
8.Pipeline Principle.....	(17)
9.Electrical wiring Diagram .....	(17)
10.After Sales Service .....	(20)



## ★ To USERS

1. This appliance is not intended for use by persons (including children) with reduced physical, sensory or mental capabilities, or lack of experience and knowledge, unless they have been given supervision or instruction concerning use of the appliance by a person responsible for their safety.
2. Children should be supervised to ensure that they do not play with the appliance.
3. If the supply cord is damaged, It must be replaced by the manufacture, its service agent or similarly qualified persons in order to avoid a hazard.
4. The installation of a residual current device (RCD) having a rated residual operating current not exceeding 30mA is advisable.
- 4.1 Use an approved flexible conduit to supply power to the heat pump where appropriate to code. For electric source capacity details please check the nameplate on machine or the installation instruction manual.
- 4.2 Electrical Grounding must be supplied congruent to national and local code, and it is prohibit using the machine without the electrical grounding. Please do not connect the grounding line to Zero line or running water pipe.
- 4.3 Refer to Electric Circuit Diagram for installing.
- 4.4 Don't use the Swimming Pool Heat Pump unit when without the grid or metal plate installed, in order to avoid any accident or abnormal operation

## ★ PRODUCT INSTRUCTION

### 1. Unit Characteristics

- **Safety and Reliability**  
Our cold & heat plunge does not consume electric to cool & heat the water, the current and water are totally separated and has got a very high safety quotient. The electric shocks, flammability, explosive possibility and other unsafe conditions which exist in electric water heaters or gas heaters don't exist in our cold & heat plunge.
- **High Efficiency and Energy Saving**  
Our cold & heat plunge extracts abundant free heat energy from air. The electric energy is only used to make the compressor to transfer energy from air to water. Hence to provide the same quantity of cold or hot water, which can save quite a lot of electricity bills for users.
- **Green Energy and Earth-friendly**  
Our cold & heat plunge utilize three types of clean energy---solar energy, air heat energy and electric energy---which initiate no harmful gases during the working process, and will not cause environmental pollution like oil, coal, gas and mines.
- **24 Hours Hot Water Supply**  
Our cold & heat plunge will not be affected by severe weather such as the overcast or rain. It can be used the whole day.
- **Durable Service Life**  
The compressor, four way valves and other primary accessories of our cold & heat plunge are all famous brand products which give a guarantee of the product quality, and prolong the life span of the water chiller/heater.
-

- Wide Field of Applications

Our cold & heat plunge has various different series of products, which can satisfy the heating or cooling demand of factories, fisheries, public swimming pools, bathing centers etc.,

- Multiple Safety Protection Devices and Functions

The unit includes compressor overload protection, overflow protection, overheating protection and 3 minutes prolonged starting machine protection, HV protection, low pressure protection, phase lack/converse protection, temperature sensor protection, and it has auto defrosting, clock and rated time on/off functions.

2. Components of the cold & heat plunge unit is made up of fluorine system and electric control system .The whole operation can be completed through the controll panel.

3. Cold & heat plunge Technical Character Parameters

Model No.		RWH450-010QSC	RWH450-010QAC	RWH450-010ESC	RWH451-010QSC	RWH451-010ESC
Rated Heating Production Capacity	W	3500			3500	
Refrigerating Capacity	W	2500			2500	
Max Water Outlet Temp.	°C	42			42	
Min. Water Temperature	°C	3			3	
Reted Input	W	850			850	
Rated Working Current	A	4			4	
Power Supply	V	220~240/50Hz			220~240/50Hz	
Operating Sound Level	dB (A)	52			55	
Water-Refrigerant Heat Exchanger		Titanium Tube Heat exchanger			Contact Conduction Exchanger	
Refrigerant Type		R410a or R290				
Outline Dimension	mm	1950*800*900	1950*800*900	2010*890*1175	1950*800*900	1950*800*900
Packing Dimension	mm	2000*840*1000	2000*840*1000	2080*970*1220	2000*840*1000	2080*970*1220

Data for parameter, to the actual parameters on the nameplate shall prevail

**Note:** The parameters in the form are obtained from the following working conditions:

1. Ambient temperature dry/wet-bulb temperature is 20/15°C;
2. Inlet/Outlet water temperature equals to 26/27°C;
3. Water or salt water working pressure min-max: 0.05~0.2;
4. Water or salt water working temperature min-max: 15-45°C;
5. Machine operating ambient temperature range: -5-43°C.



## ★ Outline Dimension

Refer to the following drawings for different unit dimensions:

1. RWH450-010QSC, units dimension:

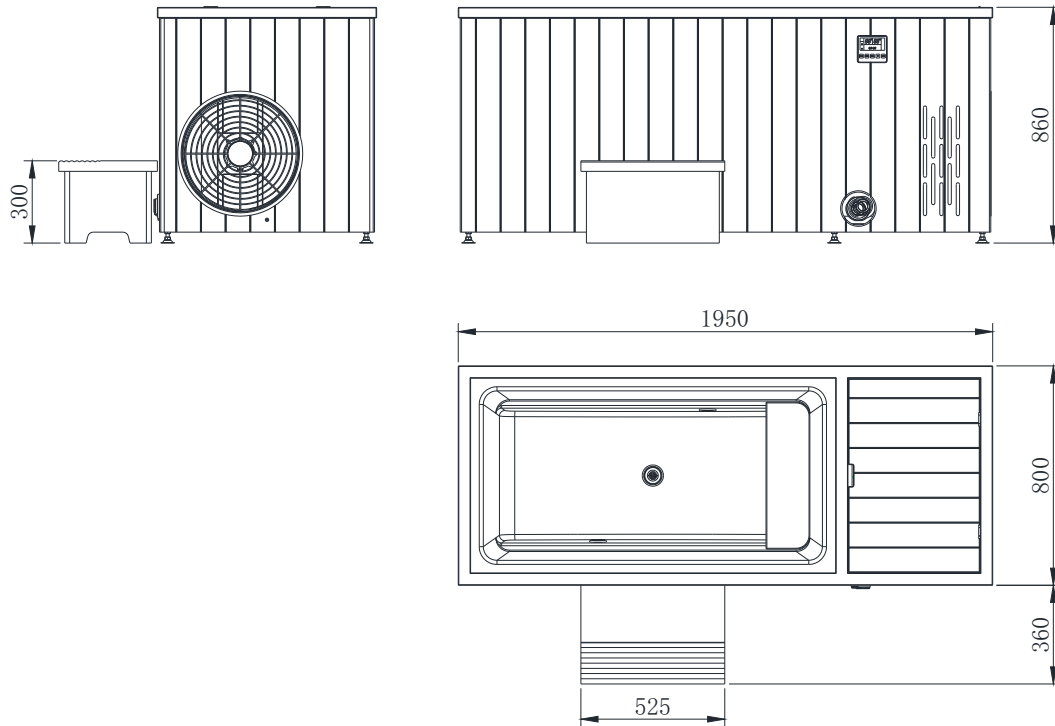

2. RWH451-010ESC, units dimension:

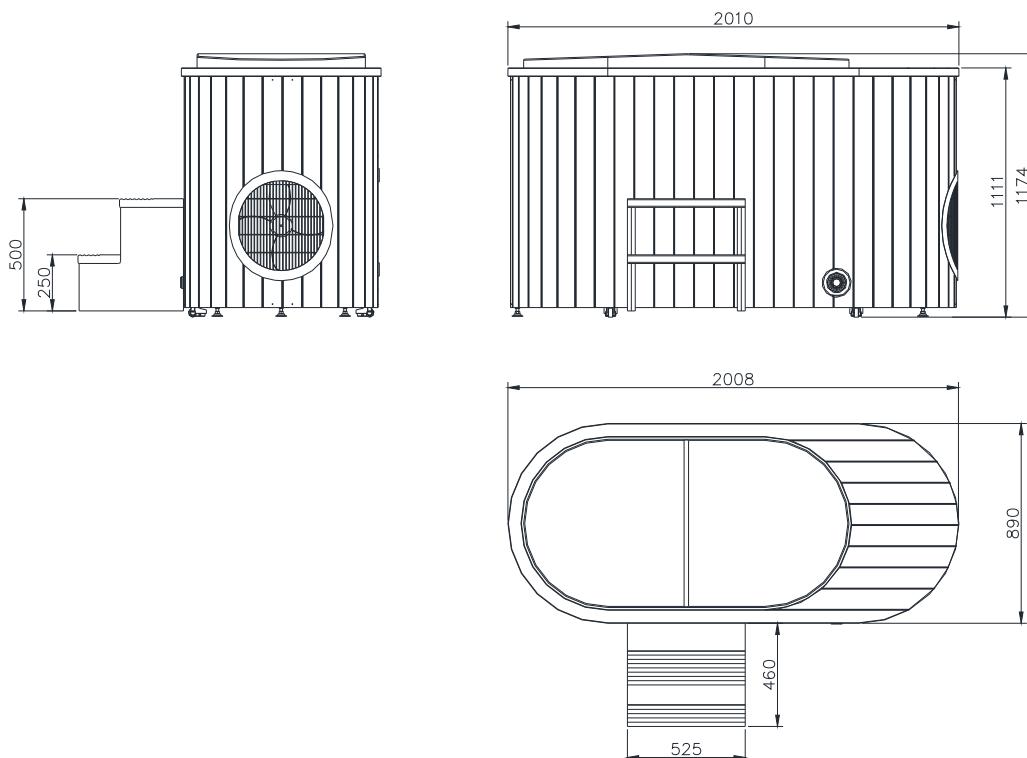



## ★ ASSEMBLY & PIPELINE CONNECTION

1. Instruction before assembly
  - 1.1 Check to assure that the appearance of the unit and the inner pipe system are not damaged in the transportation process.
  - 1.2 Check if the power supply source accords with the power source required in this manual and the nameplate on the unit.
2. Site Location and requirements.
  - 2.1 In order for the unit to operate efficiently, good ventilation of the proposed location for the unit is required. (As schematic)
  - 2.2 This water heater's fixing base must be braced, anchored, or strapped to avoid failing or moving, to ensure the flat location while installed. The system must be easy to discharge the condensed water. Adjust to make all adjustable feet to the floor. 调平脚垫（全部脚垫与地面接触），
  - 2.3 Areas where are contaminated, corrosive, dusty or near to flammable products are not suitable for water heater installation.

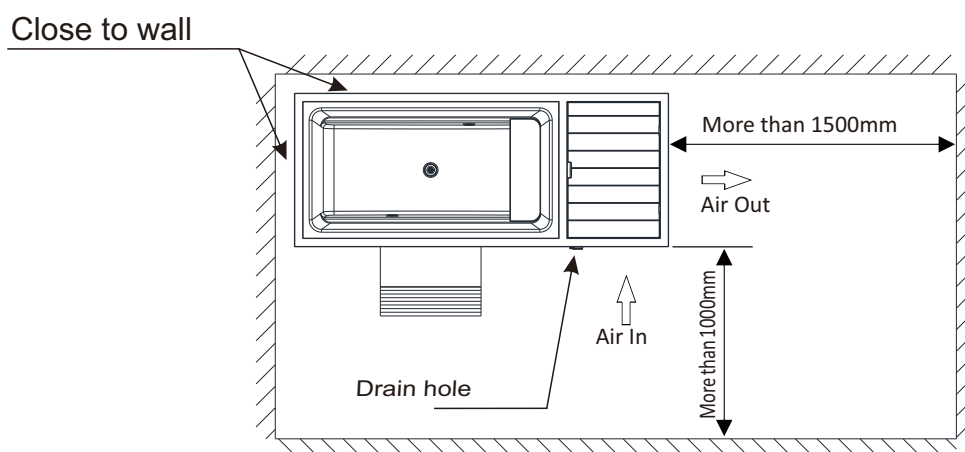

3. Electric Parts Installation Requirements
  - 3.1 Apparatus should be installed in accordance with national wiring rules.
  - 3.2 When connecting to the power supply must be used at least 3mm points from all-pole disconnection device.
  - 3.3 Construction of wiring must be installed by professional technical staff operating in accordance with the circuit diagram.
  - 3.4 In strict accordance with the electrical wiring diagram to connect the phase line, the zero line, ground, and other cables. Weak signal line and strong signal lines can not be set in the same insulated pipe, power wire size must meet the load requirements and a reliable ground and leakage protection devices are needed.
4. General Operation
  - 4.1 Fill the suitable water into the tub .
  - 4.2 Plug in the power.
  - 4.3 Run the tub according to the instruction.



# ★ INTELLIGENT CONTROLLER APPLICATION INSTRUCTION

LCD display

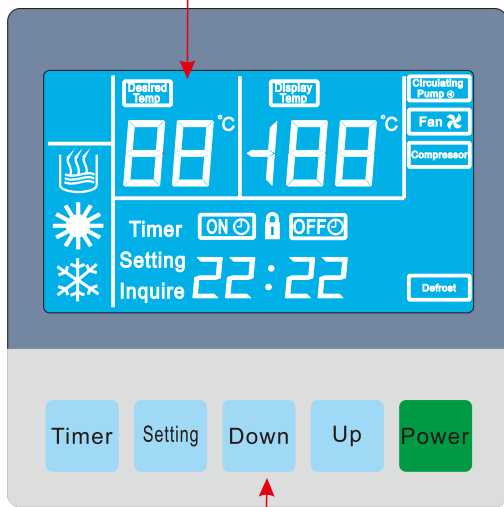

Button

## Illustration for the buttons

- power unit unlock, turn on/off
- UP increase (setting parameters of the functions)
- down decrease (setting parameters of the functions)
- setting Query and function setting
- timer Clock and timer switch setting

## ◆ Illustration for LCD display

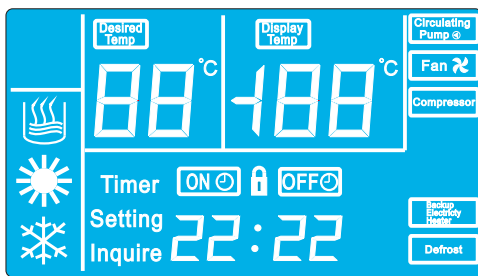

## ★ Operation mode display

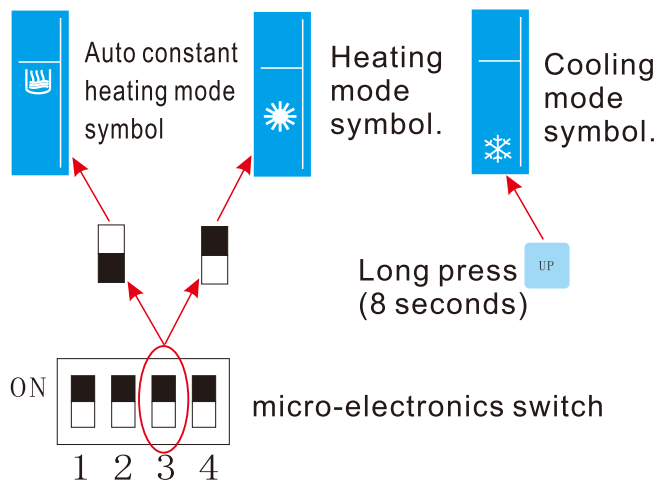

## System Default Mode: Heating Only ❄️

### ★ Output state display.

- Water pump is running symbol.
- Compressor is running symbol.
- Fan is running symbol.

- Defrosting symbol.

### ★ Water temperature display.

- Desired temperature pre-set value
- Practical pool water temperature

### ★ Timer display.

- Timer to auto start the equipment.
- Timer to auto stop the equipment

### ★ Other display

- Keyboard locked



## Operation Instruction

When the unit power on, there will be one buzzer, screen backlight on, the keyboard is locked, no button is valid.

### ◆Unlock button

Press "power" button for 3 seconds, after a sound "beep" the background lights up the keyboard is unlocked and the lock symbol disappear (non-operation for 60 seconds, keyboard will be locked automatically, the lock symbol appear)

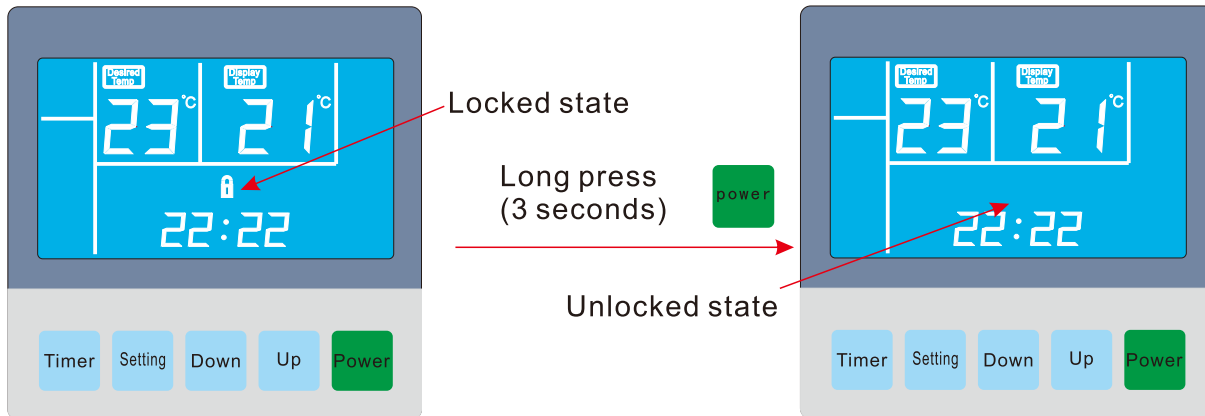

### ◆Switch on heat pump

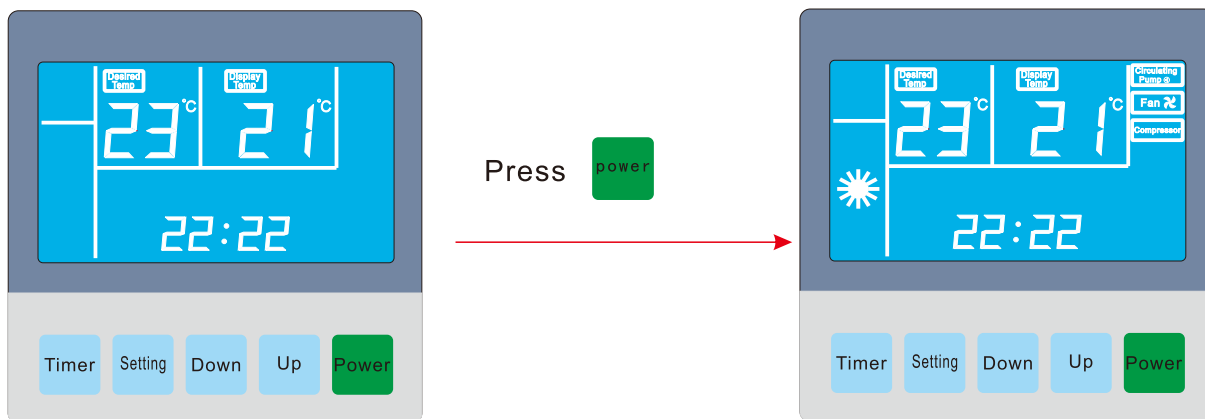

### ◆Switch off heat pump

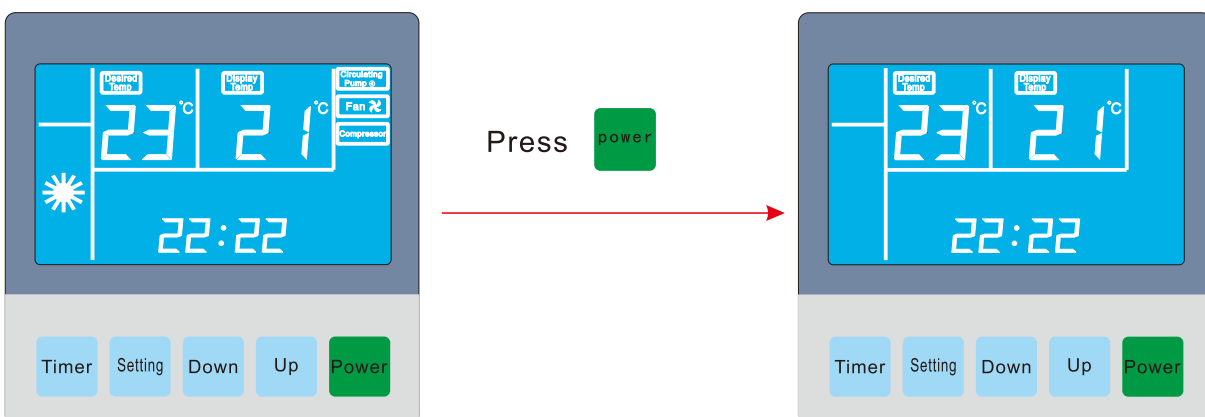





### ◆Water temperature setting

When the heat pump is switched on , just press **UP** or **down** to adjust water temperature

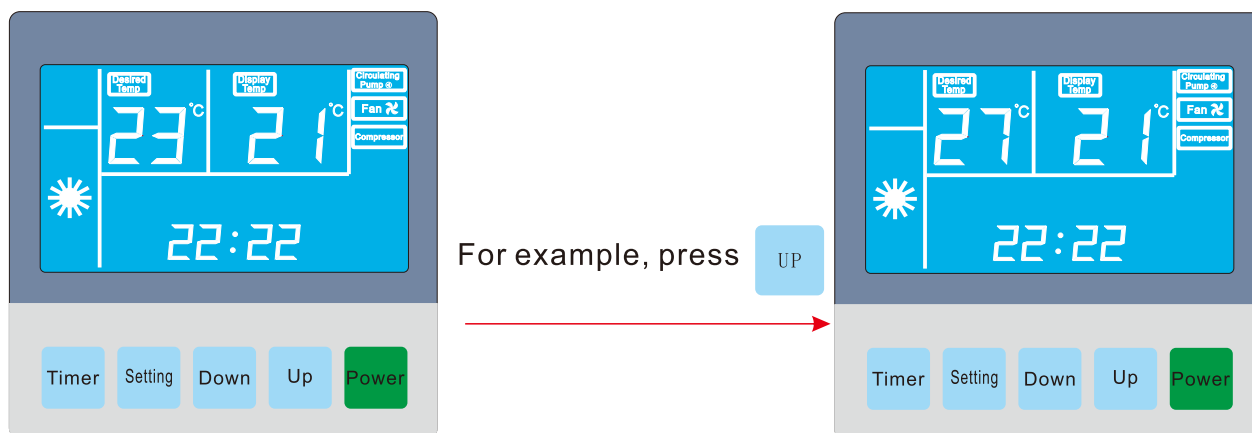

### ◆Clock setting

At the first time, the time should be defined according to local time zone;  
Otherwise, the accuracy of “Timer on/Timer off” would be influenced.

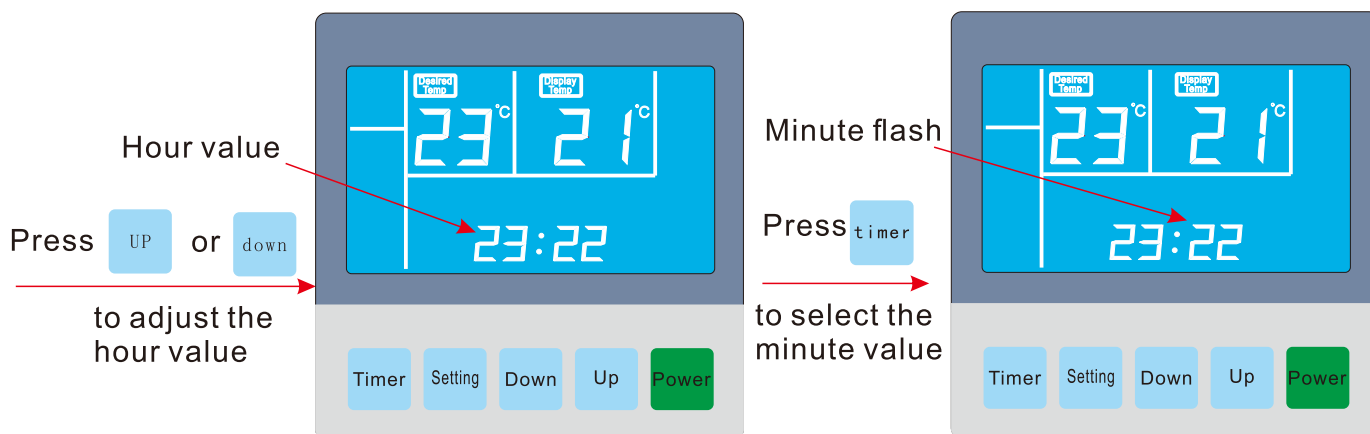
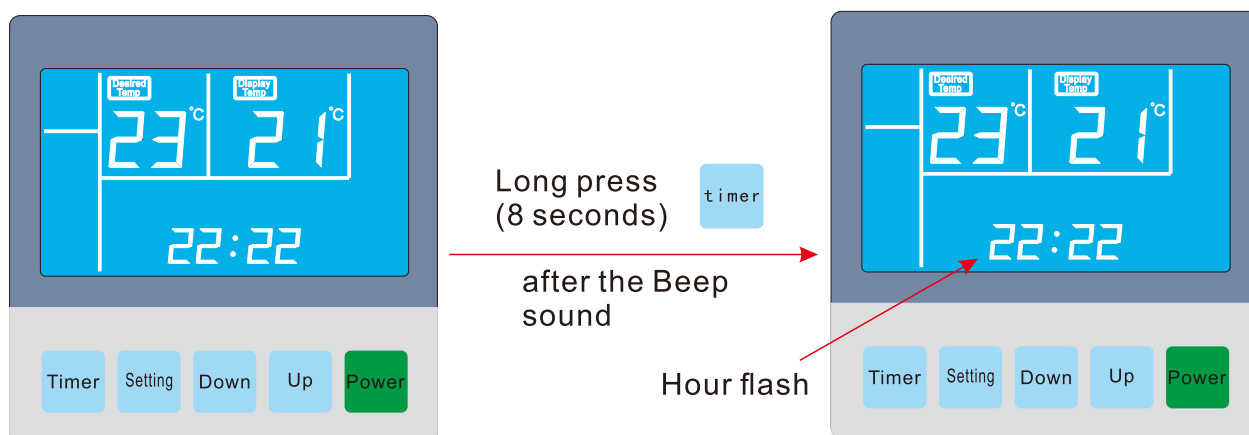

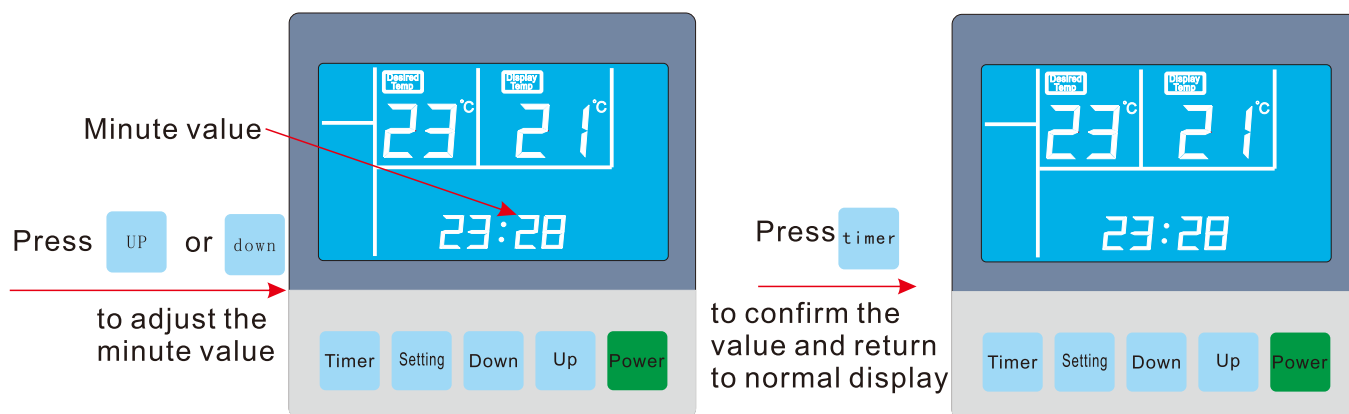

### ◆ ON/OFF timer setting

If you want to use the function of “Timer on/Timer off”, the system time has to be detected whether it is correct in advance. The setting method is referred to page 8 “◆Clock setting”.

With this function, the heat pump can turn on or turn off automatically at the set time.

When the time point of “Timer on” is arrived, the heat pump starts; thereafter, the “on/off” could be controlled automatically based on the setting temperature.

When the time point of “Timer off” is arrived, the heat pump is shut down; subsequently, the machine could no longer be controlled automatically based on the setting temperature; it will be restarted until the next time point of “Timer on” is arrived or the key is pressed.

Totally 2 ON/OFF timers can be set. And they can be applied to use for every day .

Below examples show how to set the heat pump to switch on at 13:30 and switch off at 16:30, and switch on again at 19:30 and switch off at 21:30.

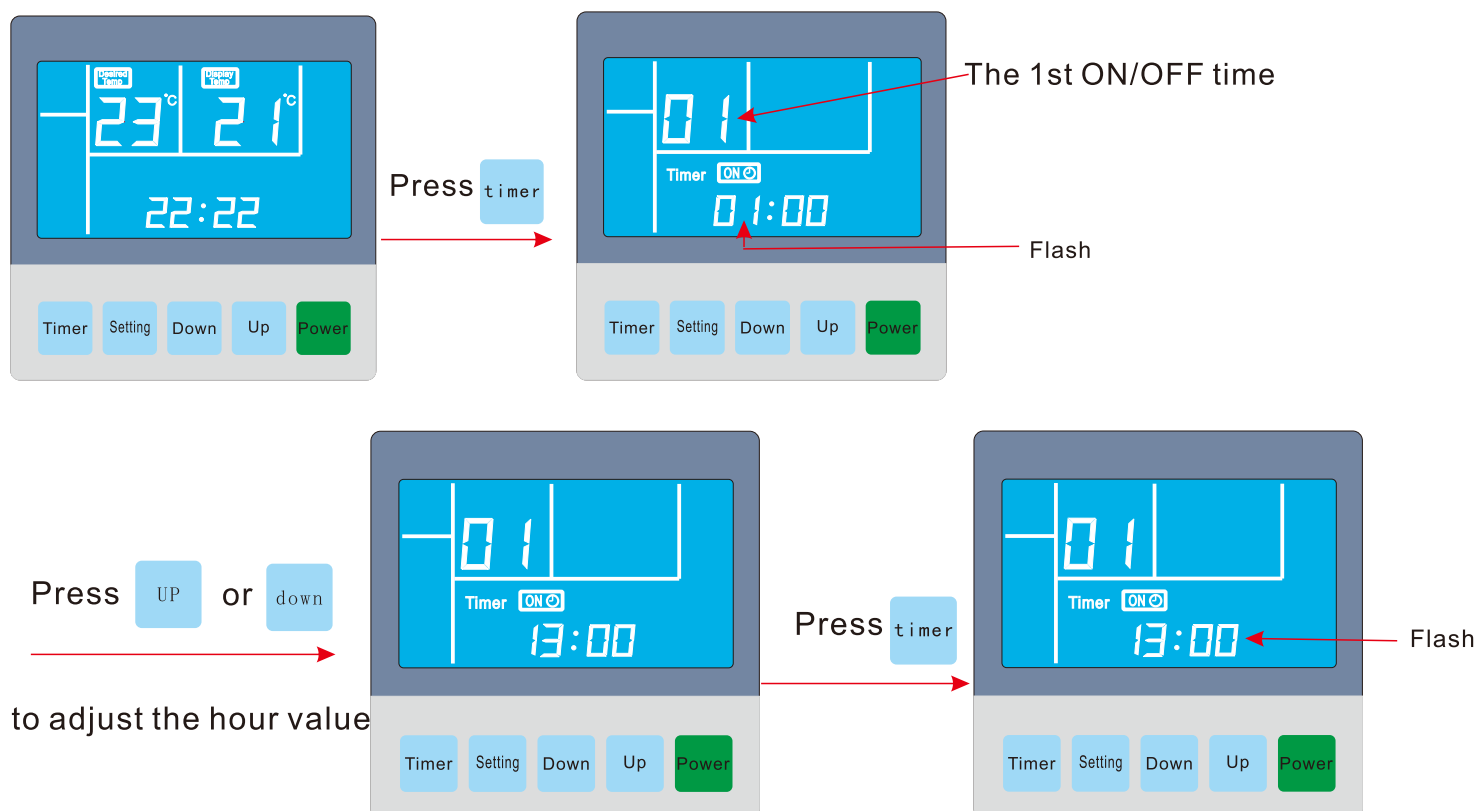

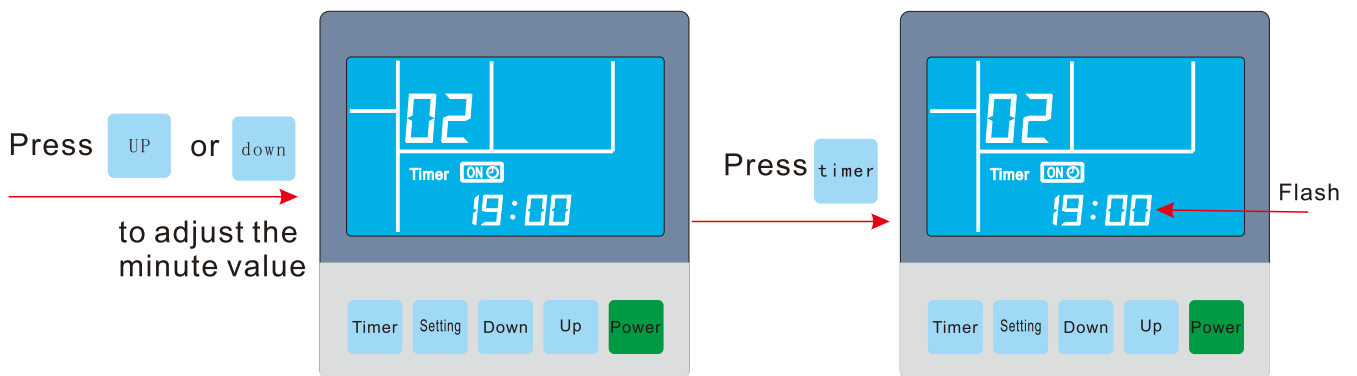
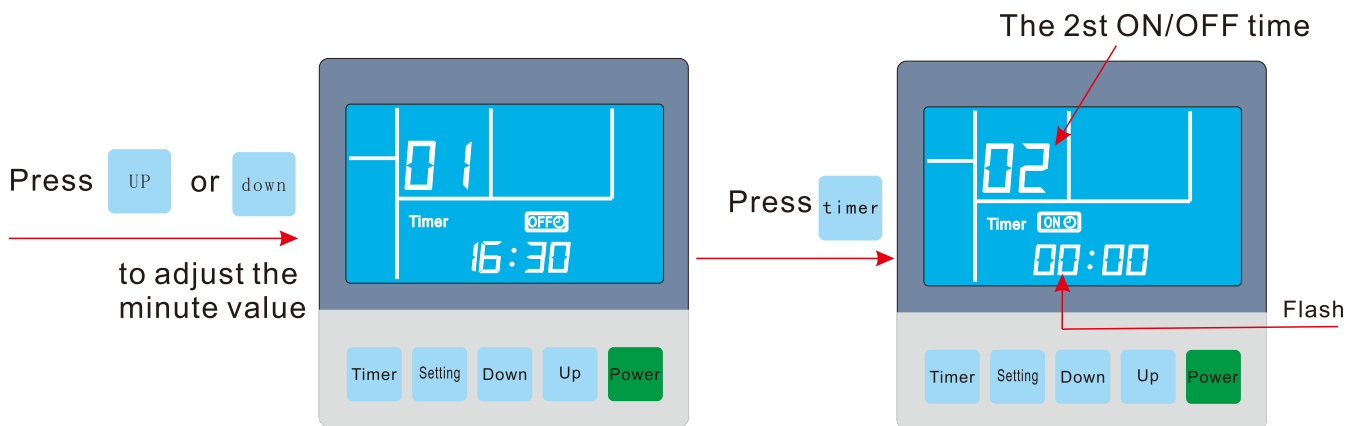
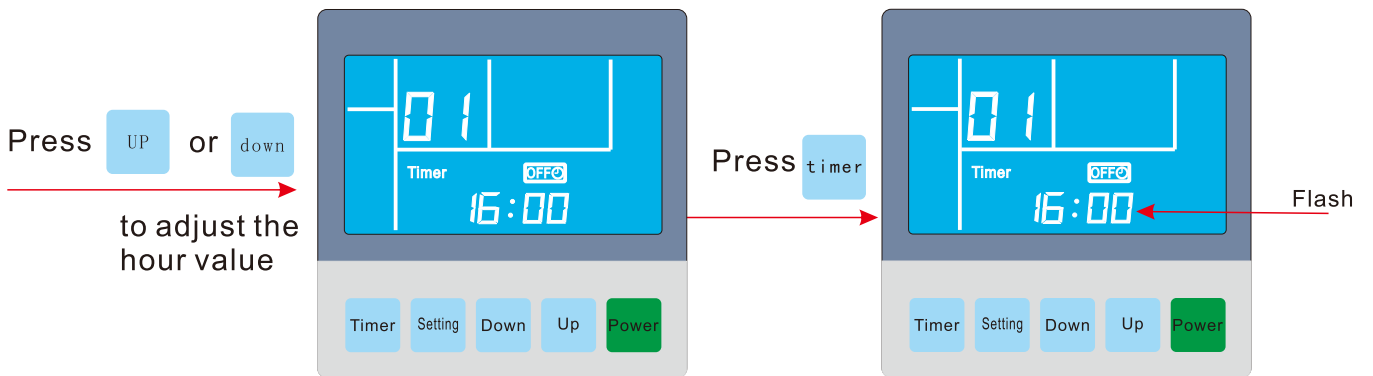
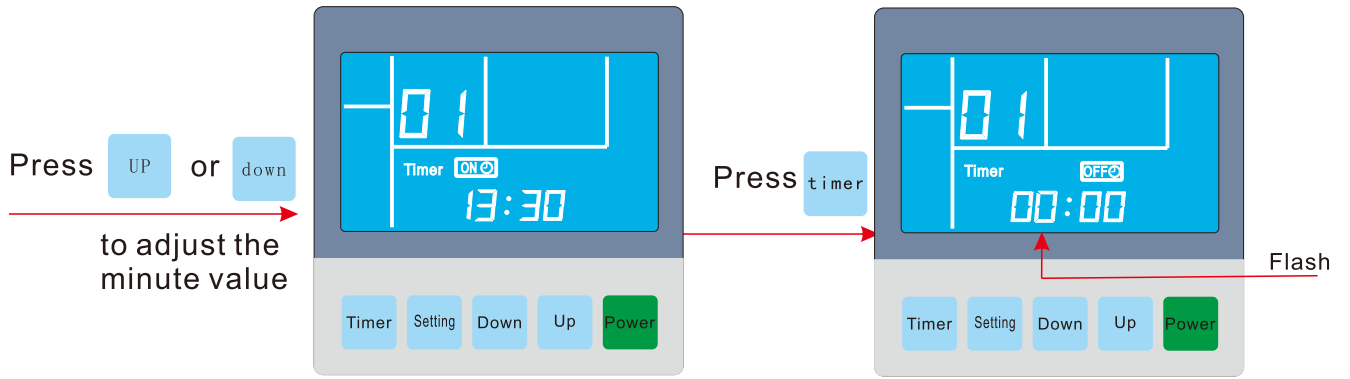

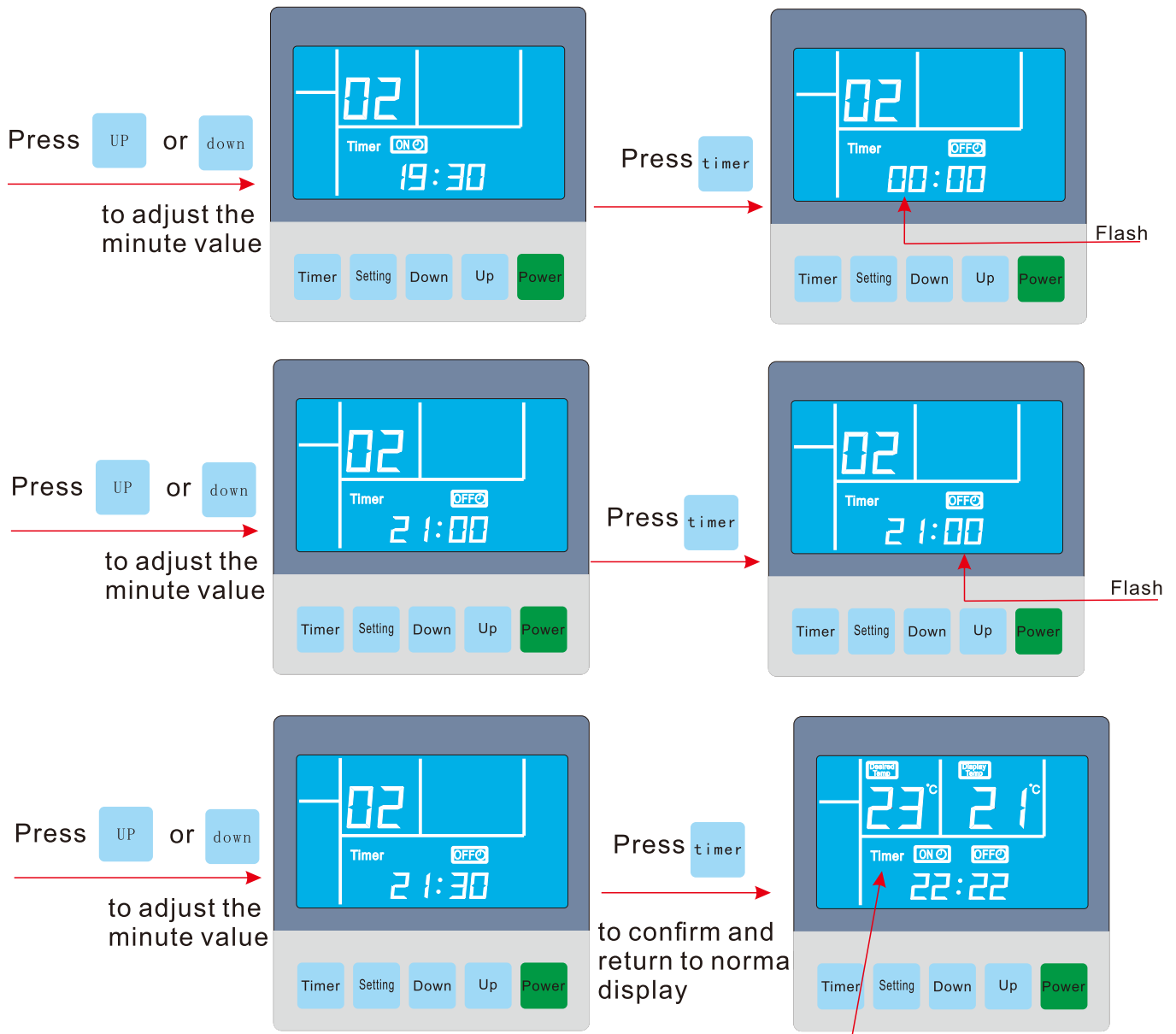

After all timer setting is finished, the set On /Off timer will be display in the time area.

### ◆ ON/OFF timer cancel setting

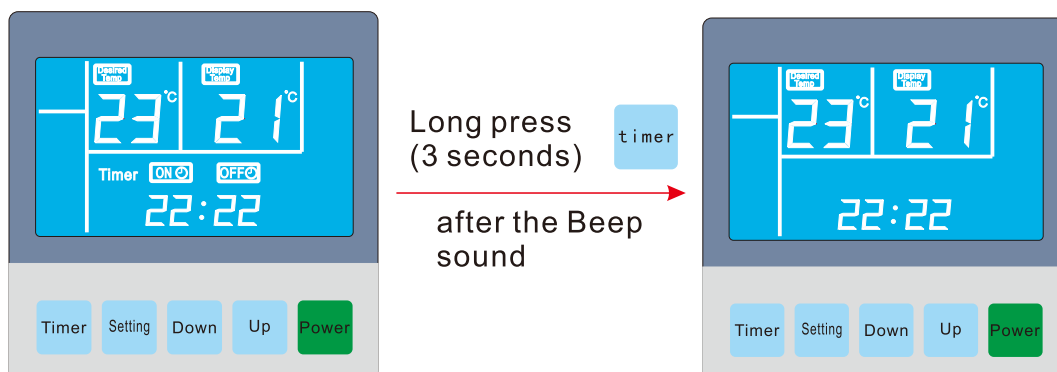



## ◆Parameter query

In normal working state, press  button to query the unit operating data.



Relevant code signification:

No	Code	Meaning	Remark
1	A1	Defrosting Temp. sensor	
2	A2	Compressor Gas- in Temp. sensor	
3	A3	Compressor Gas-out Temp. sensor	
4	A4	Ambient Temp. sensor	
5	A5	Idle	
6	A6	Idle	
7	A7	00	
8	A8	Compressor Operation Current	
9	A9	Expansion Valve Opening	
10	Er	Error Code	Standard operation shows: 00



## ◆Manual defrost setting

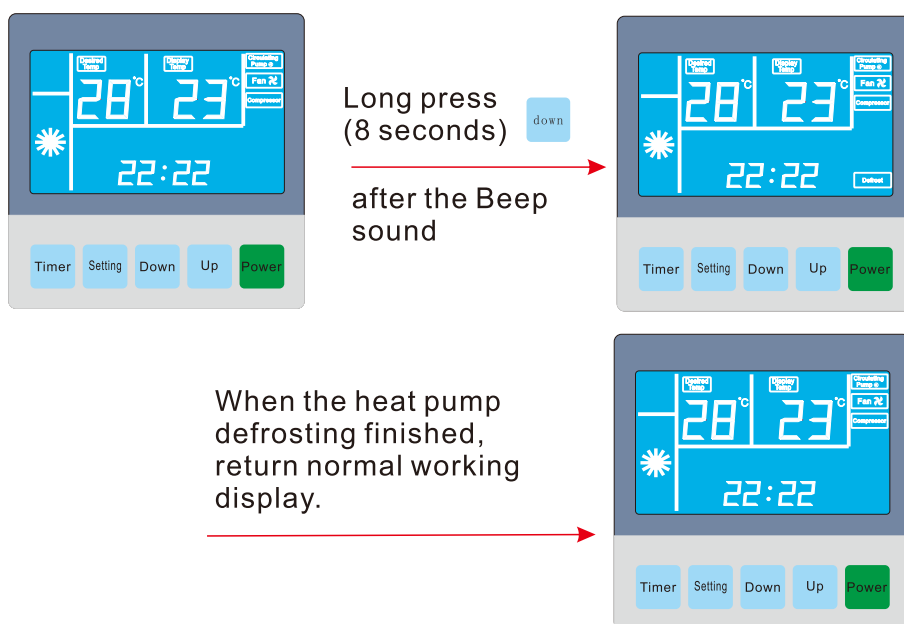

## ◆Cooling mode setting

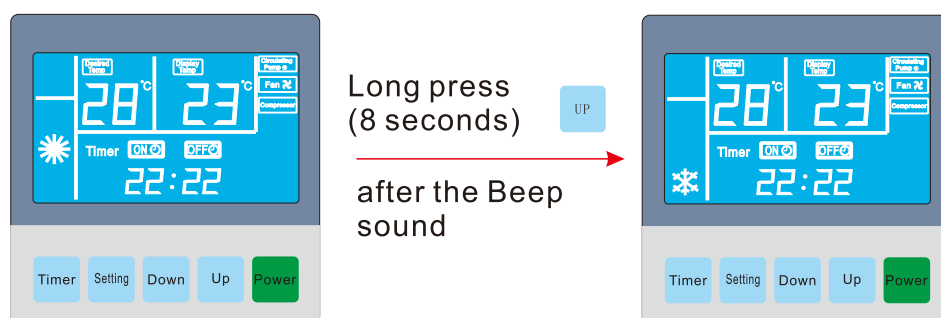

## ◆Resume heating mode setting

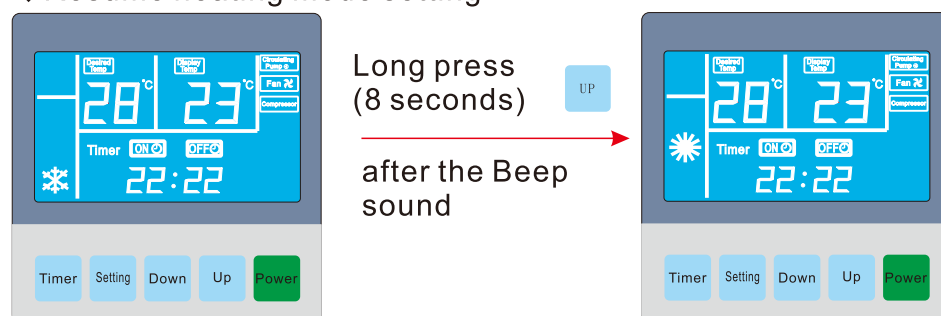



## ★ MAINTENANCE

Swimming Pool Heat Pump is a highly automatically operating instrument. It requires users to check the unit conditions regularly. If you can keep maintaining and taking good care of the unit in the long run, the reliability and service life will be improved greatly.

1. The water filter installed out of the unit should be cleaned regularly to keep the water in the system clean and avoid unit damage and jam because of the dirty filter.
2. Regularly check the electric source and the wire connections of the electric gas system of the unit and see if they are firm enough; check if there is any abnormal performance of the electric elements, and repair or change it in time if there is any problem.
3. Usually check whether the gravity feed water of the water system, the liquid level controller and the exhaust device are working well to avoid air coming into system which may lead to a reduced water circulation flow and impact the heating effects and reliable modulus of the unit.
4. Check if the water pump and water way valves are working as normal and confirm if there is no leakage of the water pipes and joints.
5. Please keep the surroundings of the unit dry, clean and well ventilated. Regularly clean the Airside Heat Exchanger to get good functioning of heat exchanging.
6. Please keep all debris and sundries away from the surroundings of the unit in order not to jam the inlet and outlet wind vents. The surroundings of the unit should be kept dry and clean and well ventilated.

## ★ UNIT PROTECTION AND TROUBLESHOOTING

1. Compressor: three minutes time-delay protection, 3 minutes for machine starting-up orl stopping, one minute to run the machine for the first power-on.
2. High voltage pressure protection: The indicator light will give an alarm when pressure fault occurs, the compressor restart to work when pressure resumed. The controller will lock the error when the pressure fault occurs again, then the compressor can not start up any more. It can start to work as soon as the error is cleared and the power is on.
3. Low voltage pressure protection: No inspection for low voltage switch during Defrostingtime, and 5 minutes delay inspection for heating and starting-up. The indicator light will give an alarm when pressure fault occurs, the compressor restart will work when pressure resumes. The controller will lock the error when the pressure fault occurs again, then the compressor can not start up any more. It can begin working as soon as the error is cleared and the power is on.
4. Three phase protection: Three-phase inspection function will generate as long as the code switch picks number. If phase misses or phase fault occurs in power-on time, all output will be closed and protected and the code error will be displayed. The power needs to be on again after the error is cleared.
5. Sensor error protection: All system will stop running (except for electric heating).
6. Auto anti-freezing: To prevent frost splitting of water tube and pump in Winter, the machine setting automatically provides freeze protection under the following conditions: a. Ambient temperature under 5°C: b. Compressor stopping over 30 min: c. Circulating water pump running 30sec.



Related error code cause and the solution, see the below table (single system):

S/N	Error code	Name	Caused by	Solutions
1	Er01	Error phase	Wrong Phase sequence	Please make sure three-phase wire is installed according to the route map and exchange optional two firewires, and confirm if there is voltage in each phase and check the power.
2	Er02	Phase shortage	Firewire doesn't output the voltage	
3	Er03	Water flow switch	1. Very little water flow; 2. Water flow switch wrong	1. Clean the tube filter and clear or replace the circulating water pump; 2. replace water flow switch;
4	Er05	High-voltage switch fault	1. Too much refrigerant; 2. Over voltage wrong display; 3. High-voltage switch fault; 4. Blocked by the dirt material or ice in the system; 5. Very little water flow;	1. To clear the extra refrigerant; 2. Whether the water temperature is too hot or expanding valve is damaged or not; 3. Replace the high-voltage switch; 4. Replace filter; 5. Clean the tube filter, clear or replace the circulating water pump;
5	Er06	Low-voltage switch fault	1. Fluorine over leakage; 2. the system is blocked by the dirt or ice; 3. low-voltage switch fault	1. Recheck and inject fluorine; 2. Replace filter; 3. replace low-voltage switch;
6	Er09	Tele-communication error	1. Loose connection of wire; 2. Wire break; 3. No signal output;	1. Pull it out and re-plug securely; 2. Check the wire break and make it well connected; 3. replace a wire;
7	Er12	Temp. of air exhaust too high	1. Poor oil return; 2. fluorine leak;	1. Replace vapor-fluid Separators or refrigeration Oil;
8	Er15	Water temp sensor fault	1. Sensor loose or falling off; 2. Sensor detector open or close circuit; 3. Poor connection of sensor pin connector	1. Fasten the sensor; 2. Replace the sensor wire. 3. Pull the connector out and re-plug securely;
9	Er16	Defrosting temp sensor fault		
10	Er18	Air exhaust temp sensor fault		
11	Er21	Environment temp sensor fault		
12	Er29	Air return temp sensor fault		
13	Er35	Compressor current protection	1. Compressor current is too large; 2. System pressure is too high	1. Check the working voltage or Replacement compressor ; 2. Reduce the system pressure

Remarks: The sensor detector parameter including water temp., environment, defrosting, gas discharge is :Temp. = 25°, Resistance = 50K;

Temp. >25°, Resistance <50K; Temp. <25°, Resistance >50K.

If there is a big difference between the actual and the theoretical resistance, you may determine that it is sensor's resistance shifting and need to replace.





## Malfunction and solution:

If malfunction happens when using, users please contact with professional repairers. The following list is for reference of the repairing work.

Malfunction Condition	Possible reasons for the malfunction	Solutions
Unit doesn't work	<ul style="list-style-type: none"> <li>◇ Power Failure</li> <li>◇ Power wire loose</li> <li>◇ Control power fuses broken</li> <li>◇ High and low pressure protection switch short-circuit</li> <li>◇ AC circuit devices or circuit board failure</li> </ul>	<ul style="list-style-type: none"> <li>◆ Disconnect the power switch, check the main circuit, power supply, voltage, whether there is electricity, or lack of phase</li> <li>◆ Identify the causes and fix it</li> <li>◆ Change a new fuses</li> <li>◆ Fix or change the switch</li> <li>◆ Fix or change circuit board</li> </ul>
Water pump is running but water doesn't circulate or water pump is too noisy.	<ul style="list-style-type: none"> <li>◇ Lack of water in Water systems</li> <li>◇ Air in Water systems</li> <li>◇ Some water valves are closed</li> <li>◇ Blocked or dirty filters</li> </ul>	<ul style="list-style-type: none"> <li>◇ Inspect the water system, and refill water</li> <li>◇ Release the air</li> <li>◇ Open water valve</li> <li>◇ Remove blockage &amp; wash filters</li> </ul>
Heating capacity of the unit is not good	<ul style="list-style-type: none"> <li>◇ Refrigerant shortage</li> <li>◇ Bad water system insulation</li> <li>◇ Bad air heat exchanger cooling</li> <li>◇ Lack of water flow</li> <li>◇ Filter blocked</li> </ul>	<ul style="list-style-type: none"> <li>◇ Check leakage and recharge refrigerant</li> <li>◇ Check the heat preservation</li> <li>◇ Wash air heat exchanger</li> <li>◇ Clean or change filter</li> </ul>
Compressor doesn't work	<ul style="list-style-type: none"> <li>◇ Power supply failure .</li> <li>◇ Compressor contactor is damaged Loose wiring.</li> <li>◇ Compressor overheat protection .</li> <li>◇ High and low pressure protection switch short-circuit .</li> <li>◇ Water overheat protection</li> <li>◇ Lack of water flow</li> </ul>	<ul style="list-style-type: none"> <li>◇ Identify the causes and correct</li> <li>◇ Change compressor contactor</li> <li>◇ Identify the loose point and correct</li> <li>◇ Check the exhaust temperature protection switch open circuit or not, to identify the reasons for overheating before using</li> <li>◇ Fix or change the switch</li> <li>◇ Reset the outlet water temp</li> <li>◇ Wash filters and release air</li> </ul>
Too much running noise of the compressor	<ul style="list-style-type: none"> <li>◇ Liquid refrigerant into the compressor</li> <li>◇ Insufficient lubrication.</li> <li>◇ Compressor internal parts damaged</li> </ul>	<ul style="list-style-type: none"> <li>◇ Check whether the expansion valve failure</li> <li>◇ Add oil</li> <li>◇ Change Compressor</li> </ul>
Fan doesn't work	<ul style="list-style-type: none"> <li>◇ Fan screw loose</li> <li>◇ Electrical burn</li> <li>◇ Contactor damage</li> </ul>	<ul style="list-style-type: none"> <li>◇ Tighten fan screw</li> <li>◇ Change the fans</li> <li>◇ Change contactor</li> </ul>
Compressor is running but the unit doesn't produce heat	<ul style="list-style-type: none"> <li>◇ Refrigerant totally leaked</li> <li>◇ Compressor Fault</li> </ul>	<ul style="list-style-type: none"> <li>◇ Leakage check and add refrigerant</li> <li>◇ change compressor</li> </ul>
The compressor stops working immediately after turning on	<ul style="list-style-type: none"> <li>◆ Air in the system caused high pressure increases, which turns off the protection Switch.</li> <li>◆ Excessive refrigerant.</li> <li>◆ Abnormal power supply voltage or not enough diameter wire, excessive power supply circuits caused small starting current.</li> <li>◆ High and low pressure portection switch malfunction or air exhaust temp protection switch malfunction.</li> </ul>	<ul style="list-style-type: none"> <li>◇ Vacuum and add refrigerant</li> <li>◇ Discharge excess refrigerant</li> <li>◇ Return to normal power supply</li> <li>◇ Return to normal power supply</li> <li>◇ Change switch</li> </ul>
Lack of Water flow	<ul style="list-style-type: none"> <li>◇ Lack of water flow</li> <li>◇ Dirty or blocked filters</li> </ul>	<ul style="list-style-type: none"> <li>◇ Check the water pump</li> <li>◇ Wash the filter and release air</li> </ul>
Exhaust pressure is too high	<ul style="list-style-type: none"> <li>◇ Excessive refrigerant</li> <li>◇ Air in the system (Air-type non-condensable gas)</li> <li>◇ Lack of water flow</li> <li>◇ Excessive scale in condenser</li> </ul>	<ul style="list-style-type: none"> <li>◇ Discharge excess refrigerant</li> <li>◇ Discharge non-condensable gas</li> <li>◇ Check water system and increase water flow</li> <li>◇ Clean condenser</li> </ul>
Inlet pressure is too low	<ul style="list-style-type: none"> <li>◇ Lack of refrigerant</li> <li>◇ Circulating water temperature or the ambient temperature is too low</li> <li>◇ Pressure drop through the heat exchanger</li> </ul>	<ul style="list-style-type: none"> <li>◇ Filling amount of refrigerant</li> <li>◇ After the water is back to the temperature, and then check the pressure</li> <li>◇ Check expansion valve opening</li> </ul>
Compressor/circulation pump is running but fan doesn't work	<ul style="list-style-type: none"> <li>◇ Fan motor fault</li> <li>◇ Fan Capacitor Failure</li> </ul>	<ul style="list-style-type: none"> <li>◇ Fix or change fan motor</li> <li>◇ Change the Fan Capacitor in same model</li> </ul>
Fuse melts after switch on or electric leakage switch trips	<ul style="list-style-type: none"> <li>◇ Compressor coil burnt or inter-turn short-circuit</li> <li>◇ Compressor choked</li> <li>◇ Electrical leakage</li> </ul>	<ul style="list-style-type: none"> <li>◇ Change Compressor</li> <li>◇ Change Compressor</li> <li>◇ Check lines and electrical appliances</li> </ul>



## ★ Pipeline Principle

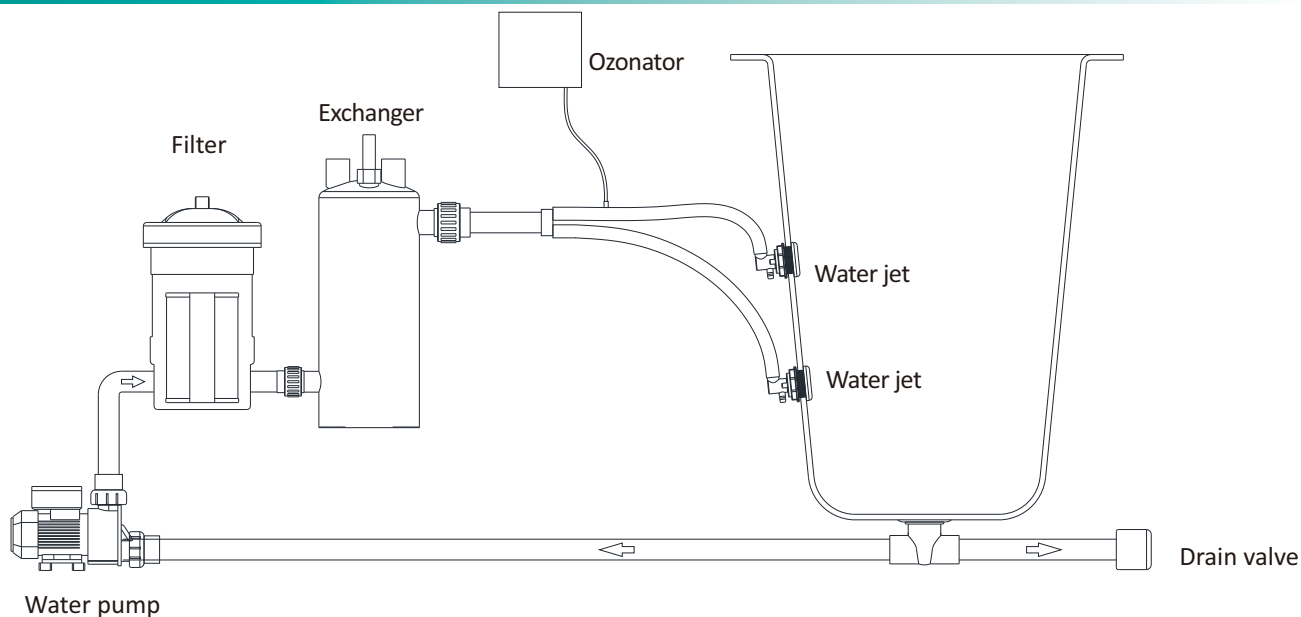

## ★ ELECTRIC WIRING DIAGRAM

Attention: Fuse models: F5AL 250V~5A

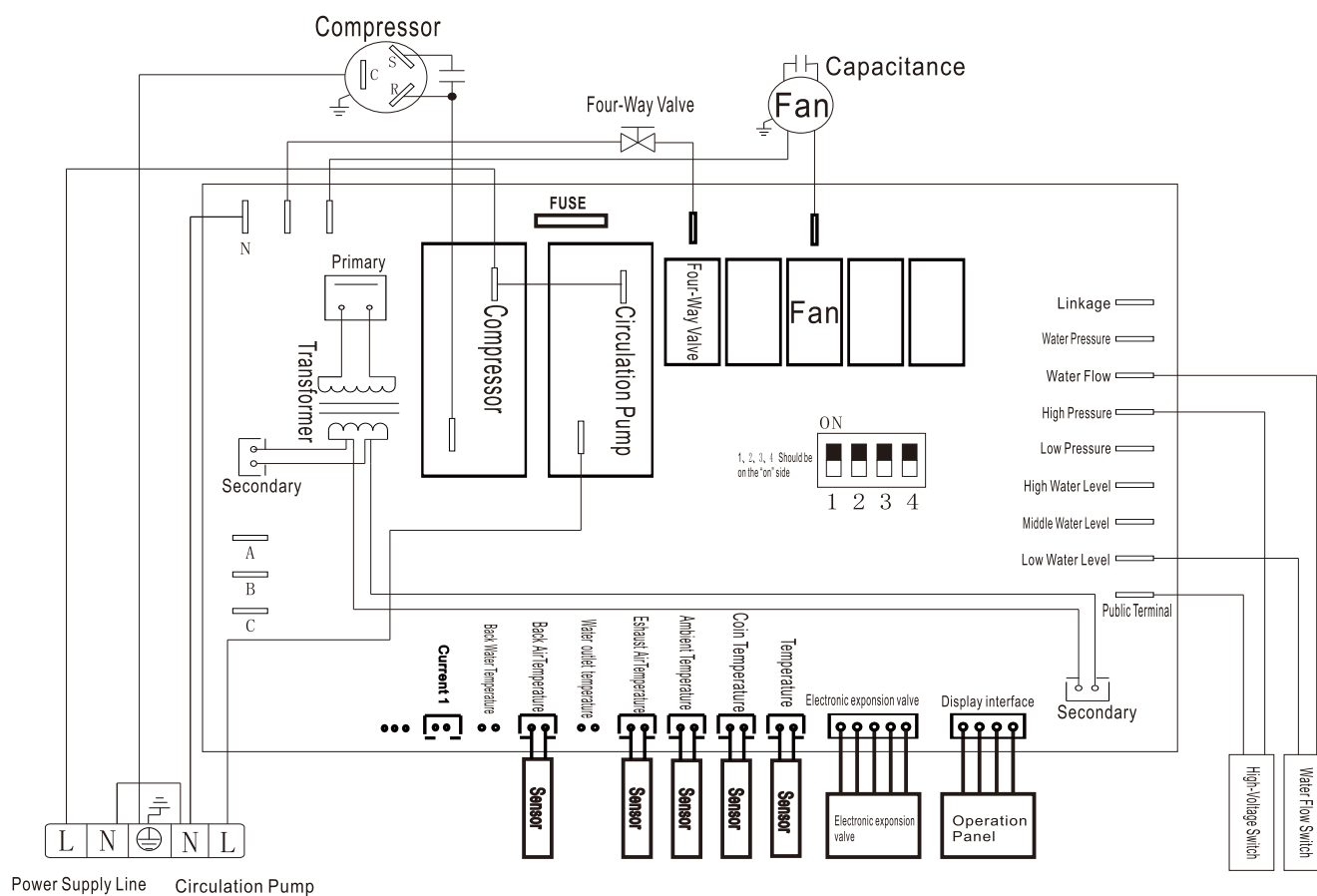

Reference only, For installation, please see to the wiring diagram pasted on the unit.

## ★ AFTER SALES SERVICE

If you encountered any problems while using the Heat Pump Water Heater, please check it according to our general troubleshooting table first. You can contact service department or distributor, when problems still here, they will provide you the solution. Thanks!

- As the products are improved constantly, the description of the content may vary accordingly somewhat from time to time. Please make the object as the standard.
  - Sorry it is not always possible to specify changes in advance.
-